

Makita[®]

12V_{max}
LITHIUM-ION

牧田 12V_{max} 鋰電工具系列



一電多機 環保之選
強力輕巧

充電式電錘套裝 16 mm (5/8")

HR166DWMX1 SDS-PLUS四坑柄



鑽牆掛畫



裝嵌傢俬



製作DIY小手工

一套便可應付！
日常家居所需！



套裝包括：

- 8枝SDS-PLUS 四坑鋼材鑽頭
- 5枝SDS-PLUS 四坑石屎鑽頭
- 5枝SDS-PLUS 四坑木材鑽頭
- 40枝25mm錐頭
- 4枝套筒
- 1枝導角刀
- 1枝磁力錐頭托座
- HR166D充電式電錘一枝
- 12V、4.0Ah電池一粒
- 充電器(DC10WD)一個
- 拉尺一個
- 毛巾一條
- 潤滑油一支
- 攜帶箱一個



BL MOTOR
無碳刷馬達

HR166DWMX1附送**64款**獨特的四坑柄配件，即插即用！

SDS-PLUS四坑柄

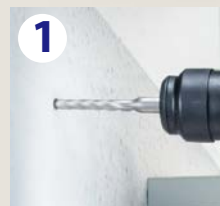

1 鑽混凝土

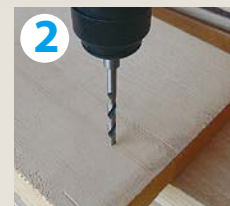

2 鑽木材

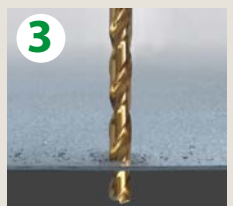

3 鑽金屬



4 扳手套筒



5 批嘴



6 導角刀

Makita

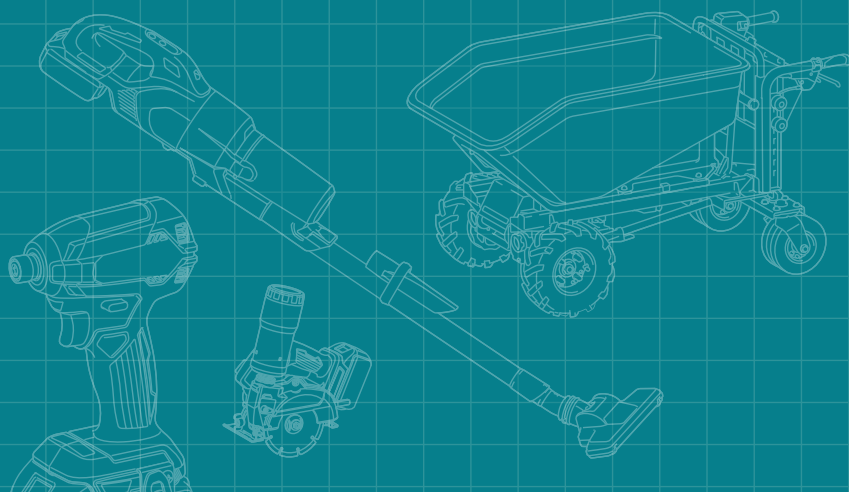
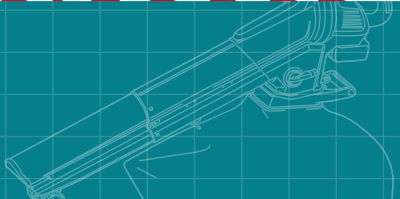

充電式起子電鑽

Li-ion Ah 4.0 2.0

DF333DSAE / DF333DZ (淨機) 10 mm (3/8")

DF033DZ (淨機) 6.35 mm (1/4")

工具運作超出負荷時會立即停機，防止扭傷手部。



DF333D
免匙索頭

DF033D
波子索頭



DF333DSAE



DF333DZ /
DF033DZ



DF333DZ



十字批嘴

能力	鋼材：10 mm (3/8") 木材：21 mm (13/16")
回轉數 (rpm)	高：0 - 1,700 低：0 - 450
最大轉矩	硬接頭 / 軟接頭： 30 / 14 N.m

體積 (長 x 寬 x 高)	DF333D：179 x 66 x 229 mm (7" x 2-5/8" x 9")
	DF033D：149 x 66 x 229 mm (5-7/8" x 2-5/8" x 9")
淨重 (連電池)	DF333D：1.2 kg (2.7 lbs.) DF033D：1.1 kg (2.4 lbs.)

DF333DSAE：快速充電器 (DC10SB) 及 2.0Ah 電池 2 顆
DF333DZ / DF033DZ：隨機不包括電池、充電器及攜帶箱，需另行購買

充電式起子電鑽

Li-ion Ah 4.0 2.0

DF332DSME / DF332DSAE

DF332DZ (淨機) 10 mm (3/8")

採用無碳刷馬達，力量強大。



DF332DSME /
DF332DSAE



DF332DZ



DF332DZ



十字批嘴

能力	鋼材：10 mm (3/8") 木材：28 mm (1-1/8")
回轉數 (rpm)	高：0 - 1,500 低：0 - 450
最大轉矩	硬接頭 / 軟接頭： 35 / 21 N.m

體積 (長 x 寬 x 高)	154 x 66 x 217 mm (6-1/6" x 2-5/8" x 8-1/2")
淨重 (連電池)	1.1 kg (2.4 lbs.)

DF332DSME：快速充電器 (DC10SB) 及 4.0Ah 電池 2 顆
DF332DSAE：快速充電器 (DC10SB) 及 2.0Ah 電池 2 顆
DF332DZ：隨機不包括電池、充電器及攜帶箱，需另行購買

充電式起子電鑽

Li-ion Ah 4.0 2.0

DF032DSME / DF032DSAE

DF032DZ (淨機) 10 mm (3/8")

採用無碳刷馬達，力量強大。



DF032DSME /
DF032DSAE



DF032DSME /
DF032DSAE



DF032DZ



十字批嘴

能力	鋼材：10 mm (3/8") 木材：28 mm (1-1/8")
回轉數 (rpm)	高：0 - 1,500 低：0 - 450
最大轉矩	硬接頭 / 軟接頭： 35 / 21 N.m

體積 (長 x 寬 x 高)	124 x 66 x 217 mm (4-7/8" x 2-5/8" x 8-1/2")
淨重 (連電池)	1.0 kg (2.3 lbs.)

DF032DSME：快速充電器 (DC10SB) 及 4.0Ah 電池 2 顆
DF032DSAE：快速充電器 (DC10SB) 及 2.0Ah 電池 2 顆
DF032DZ：隨機不包括電池、充電器及攜帶箱，需另行購買

充電式衝擊電鑽

Li-ion Ah 4.0 2.0

HP332DSME / HP332DSAE / HP332DZ (淨機) 10 mm (3/8")

採用無碳刷馬達，力量更大！



HP332DSME /
HP332DSAE



HP332DZ



十字批嘴

能力	鋼材：10 mm (3/8") 木材：28 mm (1-1/8")
衝擊數 (ipm)	高：0 - 25,500 低：0 - 6,750
回轉數 (rpm)	高：0 - 1,500 低：0 - 450
最大轉矩	硬接頭 / 軟接頭：35 / 21 N.m

體積 (長 x 寬 x 高)	168 x 66 x 217 mm (6-5/8" x 2-5/8" x 8-1/2")
淨重 (連電池)	1.1 kg (2.4 lbs.)

HP332DSME：快速充電器 (DC10SB) 及 4.0Ah 電池 2 顆
HP332DSAE：快速充電器 (DC10SB) 及 2.0Ah 電池 2 顆
HP332DZ：隨機不包括電池、充電器及攜帶箱，需另行購買

充電式衝擊電鑽

Li-ion Ah 4.0 2.0

HP333DSAX1 / HP333DSAE / HP333DZ (淨機) 10 mm (3/8")

馬力更大，扭力更高！



HP333DSAX1



HP333DSAE



HP333DZ



十字批嘴

能力	鋼材：10 mm (3/8") 木材：21 mm (13/16") 磚材：8 mm (5/16")
衝擊數 (ipm)	高：0 - 25,500 低：0 - 6,750
回轉數 (rpm)	高：0 - 1,700 低：0 - 450
最大轉矩	硬接頭 / 軟接頭：30 / 14 N.m

體積 (長 x 寬 x 高)	193 x 66 x 229 mm (7-5/8" x 2-5/8" x 9")
淨重 (連電池)	1.3 kg (2.9 lbs.)

HP333DSAX1：74 件配件、快速充電器 (DC10SB)、2.0Ah 電池 2 顆及攜帶箱
HP333DSAE：快速充電器 (DC10SB) 及 2.0Ah 電池 2 顆
HP333DZ：隨機不包括電池、充電器及攜帶箱，需另行購買

HP333DSAX1

充電式電錘連74件配件套裝

- 74件配件
 - 8枝 HSS-R鋼材鑽頭
 - 4枝套筒
 - 5枝磚材鑽頭
 - 2枝扁平鑽頭
 - 5枝木材鑽頭
 - 1枝導角刀
 - 40枝25mm錐頭
 - 1枝磁力錐頭托座
 - 8枝50mm錐頭
- 一枝HP333D充電式衝擊電鑽
- 兩粒12V、2.0Ah電池
- 一個快速充電器(DC10SB)
- 一個攜帶箱



鑽孔 · 緊固

充電式衝擊起子機

Li-ion Ah 4.0 2.0

TD111DSME / TD111DSAE / TD111DSAEB / TD111DZ (淨機)

採用無碳刷馬達，力量強大但機身小巧！



TD111DSME /
TD111DSAE /
TD111DSAEB



TD111DZ



TD111DSAEB



十字改錐頭

能力	機械螺絲：M4 - M8 (5/32" - 5/16") 標準螺絲：M5 - M14 (3/16" - 9/16") 高張力螺絲：M5 - M12 (3/16" - 1/2") 粗牙螺絲 (長度)： 22 - 90 mm (7/8" - 3-1/2")
衝擊數 (ipm)	高 / 低：0 - 3,900 / 0 - 1,600
回轉數 (rpm)	高 / 低：0 - 3,000 / 0 - 1,300
最大轉矩	135 N.m (1,200 in.lbs)
體積 (長 x 寬 x 高)	135 x 66 x 210 mm (5-5/16" x 2-5/8" x 8-1/4")
淨重 (連電池)	0.97 kg (2.1 lbs.)

TD111DSME：快速充電器 (DC10SB) 及 4.0Ah 電池 2 顆
TD111DSAE / TD111DSAEB：快速充電器 (DC10SB) 及 2.0Ah 電池 2 顆
TD111DZ：隨機不包括電池、充電器及攜帶箱，需另行購買



充電式衝擊起子機 TD111D

充電式衝擊起子機

Li-ion Ah 4.0 2.0

TD110DSAE / TD110DZ (淨機)

機身設計符合人類手形，容易握緊！



TD110DSAE



TD110DZ



十字改錐頭

能力	機械螺絲：M4 - M8 (5/32" - 5/16") 標準螺絲：M5 - M12 (3/16" - 1/2") 高張力螺絲：M5 - M10 (3/16" - 3/8") 粗牙螺絲 (長度)： 22 - 90 mm (7/8" - 3-1/2")
衝擊數 (ipm)	0 - 3,500
回轉數 (rpm)	0 - 2,600
最大轉矩	110 N.m (970 in.lbs)
體積 (長 x 寬 x 高)	153 x 66 x 204 mm (6" x 2-5/8" x 8-1/8")
淨重 (連電池)	1.0 kg (2.2 lbs.)

TD110DSAE：快速充電器 (DC10SB) 及 2.0Ah 電池 2 顆
TD110DZ：隨機不包括電池、充電器及攜帶箱，需另行購買

充電式角向電鑽

Li-ion Ah 4.0 2.0

DA333DSAE / DA333DZ (淨機) 10 mm (3/8")

機身輕巧，適合於狹窄空間使用！



DA333DSAE



DA333DZ



夾頭匙 · +- 改錐頭

能力	鋼材：10mm (3/8") 木材：12mm (1/2")
回轉數 (rpm)	0 - 1,100
體積 (長 x 寬 x 高)	313 x 68 x 95 mm (12-3/8" x 2-11/16" x 3-3/4")
淨重 (連電池)	1.2kg (2.6 lbs.)

DA333DSAE：快速充電器 (DC10SB) 及 2.0Ah 電池 2 顆
DA333DZ：隨機不包括電池、充電器及攜帶箱，需另行購買

充電式角向電鑽

Li-ion Ah 4.0 2.0

DA332DSAE / DA332DZ (淨機) 10 mm (3/8")

機身輕巧，適合於狹窄空間使用！



DA332DSAE



DA332DZ



夾頭匙 · +- 改錐頭

能力	鋼材：10mm (3/8") 木材：12mm (1/2")
回轉數 (rpm)	0 - 1,100
體積 (長 x 寬 x 高)	313 x 68 x 86 mm (12-3/8" x 2-11/16" x 3-3/8")
淨重 (連電池)	1.2kg (2.6 lbs.)

DA332DSAE：快速充電器 (DC10SB) 及 2.0Ah 電池 2 顆
DA332DZ：隨機不包括電池、充電器及攜帶箱，需另行購買

充電式角向衝擊起子機

Li-ion Ah 4.0 2.0

TL064DZ (淨機)

機身纖細輕巧，適用於狹窄的地方！



十字改錐頭

能力	機械螺絲：M4-M8 (5/32" - 5/16") 標準螺絲：M4-M12 (5/32" - 7/16") 高張力螺絲：M4-M8 (5/32" - 5/16") 粗牙螺絲 (長度)： 22-75mm (7/8" - 2-31/32")
衝擊數 (ipm)	0 - 3,000
回轉數 (rpm)	0 - 2,000
最大轉矩	60 N.m (531 in.lbs.)
體積 (長 x 寬 x 高)	361 x 66 x 86 mm (14-1/4" x 2-5/8" x 3-3/8")
淨重 (連電池)	1.3 kg (2.9 lbs.)

隨機不包括電池、充電器及攜帶箱，需另行購買。

充電式角向衝擊扳手

Li-ion Ah 4.0 2.0

TL065DZ (淨機)

工具前部能 360 度旋轉及鎖定，適合不同工作！



能力 機械螺絲: M4-M12 (5/32"-1/2")
高張力螺絲: M4-M8 (5/32"-5/16")
方形傳動螺絲: 9.5mm (3/8")

衝擊數 (ipm) 0 - 3,000
回轉數 (rpm) 0 - 2,000

最大轉矩 60 N.m (531 in.lbs.)

體積 (長 x 寬 x 高) 361 x 66 x 86 mm
(14-1/4" x 2-5/8" x 3-3/8")

淨重 (連電池) 1.3 kg (2.9 lbs.)



隨機不包括電池、充電器及攜帶箱，需另行購買。



充電式棘輪扳手

Li-ion Ah 4.0 2.0

WR100DZ (淨機) 6.35mm / 9.5mm (1/4" - 3/8")

可當作手工具扳手使用。



能力 機械螺絲: M5 - M12 (3/16"-1/2")
高張力螺絲: M5 - M10 (3/16" - 3/8")
方形傳動螺絲: 6.35mm (1/4") / 9.5mm (3/8")

回轉數 (rpm) 0 - 800

最大轉矩 47.5 N.m (420 in.lbs.)

體積 (長 x 寬 x 高) 340 x 66 x 83 mm
(13-3/8" x 2-5/8" x 3-1/4")

淨重 (連電池) 1.0 kg (2.2 lbs.)



隨機不包括電池、充電器及攜帶箱，需另行購買。



配件不包括套筒

充電式扳手

Li-ion Ah 4.0 2.0

TW161DSAE / TW161DZ (淨機) 12.7mm (1/2")

牧田 12V 扳手，最大轉矩可達 165 N.m！



能力 標準螺絲: M8-M16 (5/16"-5/8")
高張力螺絲: M6-M12 (1/4"-1/2")
方形傳動螺絲: 12.7 mm (1/2")

衝擊數 (ipm) 高: 0 - 3,600; 低: 0 - 2,000
回轉數 (rpm) 高: 0 - 2,400; 低: 0 - 1,300

最大轉矩 165 N.m (1,460 in.lbs.)
最大鬆螺母轉矩 290 N.m (2,570 in.lbs.)

體積 (長 x 寬 x 高) 150 x 66 x 213 mm
(5-7/8" x 2-5/8" x 8-3/8")

淨重 (連電池) 1.2 kg (2.7 lbs.)

TW161DSAE: 快速充電器 (DC10SB) 及 2.0Ah 電池 2 顆
TW161DZ: 隨機不包括電池、充電器及攜帶箱，需另行購買



配件不包括套筒

TW161DSAE



TW161DZ



充電式扳手

Li-ion Ah 4.0 2.0

TW141DZ (淨機) 12.7mm (1/2")

機身輕巧，最大轉矩可達 145 N.m！



能力 標準螺絲: M8-M16 (5/16"-5/8")
高張力螺絲: M6-M12 (1/4"-1/2")
方形傳動螺絲: 12.7 mm (1/2")

衝擊數 (ipm) 0 - 3,200
回轉數 (rpm) 0 - 2,600

最大轉矩 145 N.m (107 ft.lbs.)

體積 (長 x 寬 x 高) 168 x 66 x 205 mm
(6-5/8" x 2-5/8" x 8-1/8")

淨重 (連電池) 1.2 kg (2.7 lbs.)

隨機不包括電池、充電器及攜帶箱，需另行購買。



配件不包括套筒



充電式扳手

Li-ion Ah 4.0 2.0

TW140DSAE / TW140DZ (淨機) 9.5mm (3/8")

牧田首部 12V 扳手，機身輕巧，操作舒適！



能力 標準螺絲: M8-M16 (5/16"-5/8")
高張力螺絲: M6-M12 (1/4"-1/2")
方形傳動螺絲: 9.5 mm (3/8")

衝擊數 (ipm) 0 - 3,200
回轉數 (rpm) 0 - 2,600

最大轉矩 140 N.m (1,240 in.lbs.)
最大鬆螺母轉矩 290 N.m (2,390 in.lbs.)

體積 (長 x 寬 x 高) 161 x 66 x 205 mm
(6-3/8" x 2-5/8" x 8-1/8")

淨重 (連電池) 1.0 kg (2.3 lbs.)

TW140DSAE: 快速充電器 (DC10SB) 及 2.0Ah 電池 2 顆
TW140DZ: 隨機不包括電池、充電器及攜帶箱，需另行購買



配件不包括套筒

TW140DSAE



TW140DZ



充電式扳手

Li-ion Ah 4.0 2.0

TW060DZ (淨機) 6.35mm (1/4")

機身輕巧，最大轉矩可達 60 N.m！



能力 標準螺絲: M8-M16 (5/16"-5/8")
高張力螺絲: M6-M10 (1/4"-3/8")
方形傳動螺絲: 6.35 mm (1/4")

衝擊數 (ipm) 0 - 3,200

回轉數 (rpm) 0 - 2,600

最大轉矩 60 N.m (44 ft.lbs.)

體積 (長 x 寬 x 高) 161 x 66 x 224 mm
(6-3/8" x 2-5/8" x 8-7/8")

淨重 (連電池) 1.2 kg (2.7 lbs.)

隨機不包括電池、充電器及攜帶箱，需另行購買。



配件不包括套筒



鑽孔 · 緊固 · 打磨 · 切割

充電式電錘

Li-ion Ah 4.0 2.0

HR166DWMX1 / HR166DSMJ / HR166DZ (淨機) 16 mm (5/8")

牧田首創小型輕巧電錘，適合家居使用！



HR166DWMX1



HR166DSMJ



HR166DZ



2 功能模式：錘擊 + 鑽孔



側柄 · 深度規

HR166DSMJ · HR166DZ 不包括鑽嘴

能力 混凝土：16mm (5/8")
鋼材：10mm (3/8")
木材：13mm (1/2")

衝擊數 (ipm) 0 - 4,800

回轉數 (rpm) 0 - 680

體積 (長 x 寬 x 高) 250 x 74 x 206 mm
(9-7/8" x 2-15/16" x 8-1/8")

淨重 (連電池) 2.0 kg (4.4lbs.)

HR166DWMX1：64 件配件、標準充電器 (DC10WD) 及 4.0Ah 電池
HR166DSMJ：快速充電器 (DC10SB) 及 4.0Ah 電池 2 顆
HR166DZ：隨機不包括電池、充電器及攜帶箱，需另行購買



HR166DWMX1

充電式電錘連64件配件套裝

套裝包括：

- 8枝 SDS-PLUS 四坑鋼材鑽頭
- 5枝 SDS-PLUS 四坑石屎鑽頭
- 5枝 SDS-PLUS 四坑木材鑽頭
- 40枝 25mm 錐頭
- 4枝 套筒
- 1枝 導角刀
- 1枝 磁力錐頭托座
- HR166D 充電式電錘一枝
- 12V 4.0Ah 電池一粒
- 標準充電器 (DC10WD) 一個
- 拉尺一個
- 毛巾一條
- 潤滑油一支
- 攜帶箱一個



充電式玻璃切割機

Li-ion Ah 4.0 2.0

CC301DSME / CC301DZ (淨機) 85mm (3-3/8")

重量僅 1.8kg，助你靈活切割玻璃！



CC301DSME



CC301DZ



金剛石鋸片 (玻璃用) · 六角扳手

最大切割能力 0 度：25.5 mm (1")
45 度：16.5 mm (5/8")

鋸片直徑 85 mm (3-3/8")

回轉數 (rpm) 1,600

水瓶容量 0.5L

體積 (長 x 寬 x 高) 313 x 170 x 125 mm
(12-3/8" x 6-11/16" x 4-7/8")

淨重 (連電池) 1.8 kg (4.0lbs.)

CC301DSME：快速充電器 (DC10SB) 及 4.0Ah 電池 2 顆
CC301DZ：隨機不包括電池、充電器及攜帶箱，需另行購買



充電式拋光機 (兩用)

Li-ion Ah 4.0 2.0

PV301DZ (淨機) 75 mm (2-15/16")

輕巧易用，拋光打磨兩用！



橡膠墊 · 海綿墊 · 毡墊 · 側柄

最大能力 打磨類配件：50 mm
拋光類配件：80 mm

拋光墊直徑 打磨：46 mm
拋光：75 mm

回轉數 (rpm) 打磨：0 - 9,500
拋光：0 - 2,800

體積 (長 x 寬 x 高) 139 x 67 x 249 mm
(5-1/2" x 2-5/8" x 9-3/4")

淨重 (連電池) 1.2 kg (2.6 lbs.)

隨機不包括電池及充電器，需另行購買。



充電式多功能切割打磨機

Li-ion Ah 4.0 2.0

TM30DSAEX1 / TM30DZKX1 (淨機)

機頂設有 LED 工作燈，適合光線不足的地方工作！



TM30DSAEX1/
TM30DZKX1



六角扳手 · 扇形刀片 · 直切刀片 · 砂紙墊

每分鐘擺動次數 (opm) 6,000 - 20,000

擺動角度 左 / 右各 1.6°
(合計 3.2°)

體積 (長 x 寬 x 高) 277 x 65 x 198 mm
(10-7/8" x 2-9/16" x 3-7/8")

淨重 (連電池) 1.3 kg (2.9 lbs.)

TM30DSAEX1：快速充電器 (DC18RC) 及 5.0Ah 電池 2 顆
TM30DZKX1：隨機不包括電池、充電器及攜帶箱，需另行購買。



充電式多功能切割打磨機 TM30D

Makita

充電式往復鋸

Li-ion Ah 4.0 2.0

JR105DSAE / JR105DZ (淨機)

雙位置開關，能對應不同握法，用途廣泛。



CXT

能力 管道：50 mm (2")
木材：50 mm (2")

* 往復鋸片 / B 型曲線鋸片兩用

衝程長度 13 mm (1/2")

衝程速度 (spm) 0 - 3,300

體積 (長 x 寬 x 高) 376 x 66 x 186 mm
(14-3/4" x 2-5/8" x 7-3/8")

淨重 (連電池) 1.3 kg (2.9 lbs.)

JR105DSAE JR105DZ
2 8



往復鋸鋸片 · 六角扳手

JR105DSAE：快速充電器 (DC10SB) 及 2.0Ah 電池 2 顆
JR105DZ：隨機不包括電池、充電器及攜帶箱，需另行購買

充電式往復鋸

Li-ion Ah 4.0 2.0

JR103DSAE / JR103DZ (淨機)

雙位置開關，能對應不同握法，用途廣泛。



CXT

能力 管道：50 mm (2")
木材：50 mm (2")

* 往復鋸片專用

衝程長度 13 mm (1/2")

衝程速度 (spm) 0 - 3,300

體積 (長 x 寬 x 高) 376 x 66 x 186 mm
(14-3/4" x 2-5/8" x 7-3/8")

淨重 (連電池) 1.3 kg (2.9 lbs.)

JR103DSAE JR103DZ
2 8



往復鋸鋸片

JR103DSAE：快速充電器 (DC10SB) 及 2.0Ah 電池 2 顆
JR103DZ：隨機不包括電池、充電器及攜帶箱，需另行購買

充電式圓鋸

Li-ion Ah 4.0 2.0

HS301DSME / HS301DSAE / HS301DZ (淨機) 85mm (3-3/8")

動力愈強，切割效率愈高！



CXT

最大切割能力 0 度：25.5mm (1")
45 度：16.5mm (5/8")

鋸片直徑 85 mm (3-3/8")

回轉數 (rpm) 1,500

體積 (長 x 寬 x 高) 313 x 170 x 155 mm
(12-3/8" x 6-11/16" x 6-1/8")

淨重 (連電池) 1.6 kg (3.5 lbs.)



HS301DSME/
HS301DSAE HS301DZ
3 4



硬質合金鋸片 · 六角扳手

HS301DSME：快速充電器 (DC10SB) 及 4.0Ah 電池 2 顆
HS301DSAE：快速充電器 (DC10SB) 及 2.0Ah 電池 2 顆
HS301DZ：隨機不包括電池、充電器及攜帶箱，需另行購買

充電式蚊釘槍

Li-ion Ah 4.0 2.0

PT354DZ (淨機)

新設計螺絲形，令打釘更精準持久！



CXT

使用釘種 (蚊釘) 長度：15, 18, 25, 30, 35 mm
(5/8", 11/16", 1", 1-3/16", 1-3/8")
直徑：0.6 mm (1/32")

彈匣容量 120 pcs

體積 (長 x 寬 x 高) 231 x 66 x 226 mm
(9-1/8" x 2-5/8" x 8-7/8")

淨重 (連電池) 2.0 kg (4.4 lbs.)



六角扳手

隨機不包括電池、充電器及攜帶箱，需另行購買。

充電式曲線鋸

Li-ion Ah 4.0 2.0

JV103DSAJ / JV103DZ (淨機)

首部採用無碳刷馬達的 12Vmax 曲線鋸！



CXT
BL
MOTOR

能力 木材：90 mm (3-1/2")
鋼材：10 mm (3/8")
鋁材：20 mm (25/32")

衝程長度 23 mm (7/8")

衝程速度 (spm) 800 - 3,000

體積 (長 x 寬 x 高) 237 x 76 x 206 mm
(9-3/8" x 3" x 8-1/8")

淨重 (連電池) 1.9 kg (4.2 lbs.)

JV103DSAJ

1

JV103DZ

4



鋸片 · 六角扳手

JV103DSAJ：快速充電器 (DC10SB) 及 2.0Ah 電池 2 顆
JV103DZ：隨機不包括電池、充電器、導尺及攜帶箱，需另行購買

充電式曲線鋸

Li-ion Ah 4.0 2.0

JV101DSAE / JV101DZ (淨機)

機身非常輕巧，助你靈活作業！

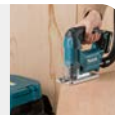

CXT

能力 木材：65 mm (2-9/16")
鋼材：2 mm (1/16")
鋁材：4 mm (5/32")

衝程長度 18 mm (11/16")

衝程速度 (spm) 0 - 2,900

體積 (長 x 寬 x 高) 232 x 76 x 196 mm
(9-1/8" x 3" x 7-3/4")

淨重 (連電池) 1.7 kg (3.8 lbs.)

JV101DSAE

3

JV101DZ

5



鋸片 · 六角扳手 · 導尺

JV101DSAE：快速充電器 (DC10SB) 及 2.0Ah 電池 2 顆
JV101DZ：隨機不包括電池、充電器、導尺及攜帶箱，需另行購買

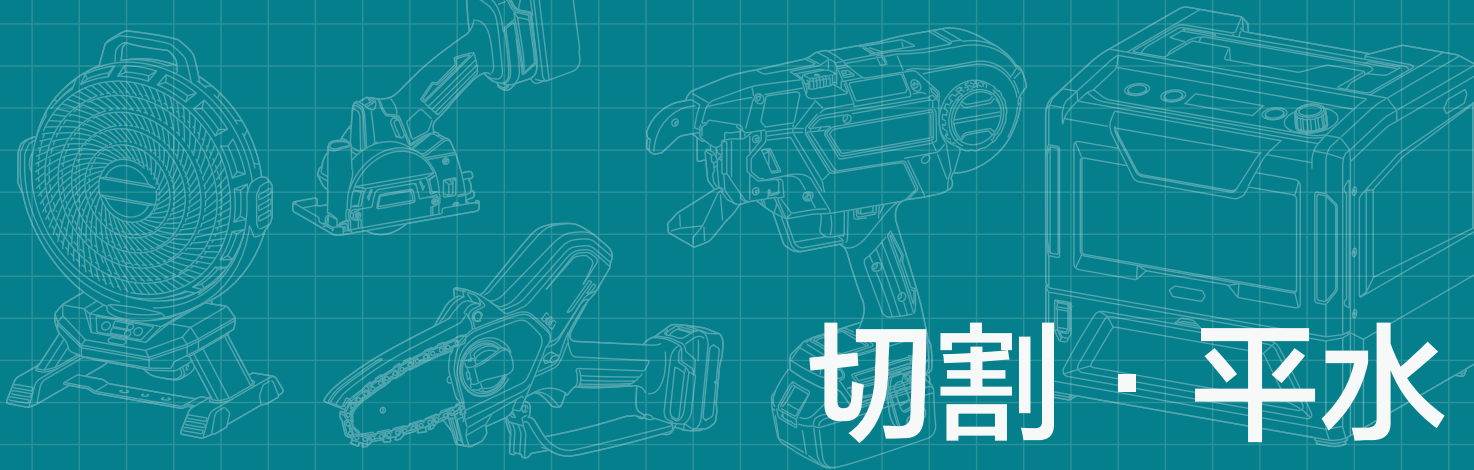

切割 · 平水

充電式平水儀

SK700GD

可使用長達**14**小時
使用12V 4.0 Ah電池



4V + 4H 雷射光束

垂直 水平



亮度選擇



雷射模式選擇 / 開關

XPT
EXTREME PROTECTION TECHNOLOGY

亮度顯示

強光 ▶ 標準 ▶ 節電模式

雷射模式選擇

無調平鎖定

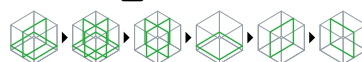

調平鎖定



於傾斜環境使用

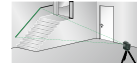

充電式平水儀

Li-ion Ah 4.0 2.0

SK700GD (淨機)

4V4H (4 條垂直、4 條水平雷射光束 360°)。

XPT
EXTREME PROTECTION TECHNOLOGY



NEW

測量精度 ±2.0 mm / 10m

自動追平 ±4°

激光種類 Laser class 2: 510-530 nm

體積 (長 x 寬 x 高) 133 x 104 x 153 mm
(5-1/4" x 4-1/8" x 6")

淨重 (連電池) 0.99 kg (2.2 lbs.)



靶板 · 適配器 · 軟包

隨機不包括電池及充電器，需另行購買。

充電式平水儀

Li-ion Ah 4.0 2.0

SK106GDZ / SK105GDZ (淨機)

1V1H + 4 光點 / 1V1H。

XPT
EXTREME PROTECTION TECHNOLOGY



SK106GDZ

SK105GDZ

NEW

測量精度 ±3.0 mm / 10m

自動追平 ±4°

激光扇角 水平：180°
垂直：170°

激光種類 Laser class 2: 525 nm

體積 (長 x 寬 x 高) 138 x 64 x 102 mm
(5-7/16" x 2-1/2" x 4")

淨重 (連電池) 0.69 kg (1.5 lbs.)

隨機不包括電池及充電器，需另行購買。



雷射目標板 · 適配器 · 收納袋

充電式平水儀

Li-ion Ah 4.0 2.0

SK40GDZ / SK20GDZ / SK10GDZ (淨機)

4V1H / 2V1H / 1V1H。

XPT
EXTREME PROTECTION TECHNOLOGY



NEW

測量精度 ±1.0 mm / 10m

自動追平 ±4°

激光扇角 水平：110°
垂直：130°

激光種類 Laser class 2: 515 nm

體積 (長 x 寬 x 高) 98 x 223 mm

淨重 (連電池) 1.4 kg (3.1 lbs.)

隨機不包括電池及充電器，需另行購買。



激光檢測器 · 激光接收器固定器 · 激光觀察鏡 · 肩帶 · 收納盒

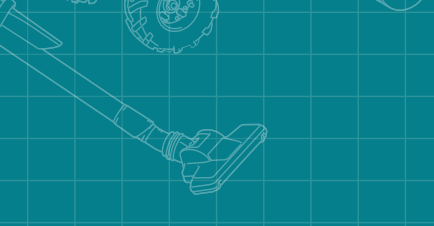
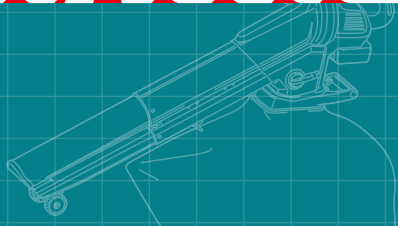

塵袋式吸塵機安裝方法



充電式吸塵機



CL121D

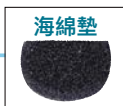

海綿墊

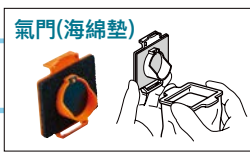

氣門(海綿墊)

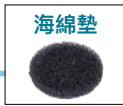

海綿墊



紙塵袋

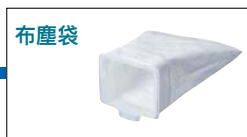

布塵袋

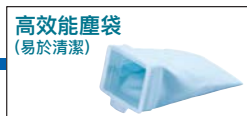

高效能塵袋
(易於清潔)

充電式吸塵機 (塵袋式)

Li-ion Ah 2.0

CL115FDWR1 / CL115FDWP1

備有直管緊鎖按鈕，直管不易與吸塵機鬆脫。

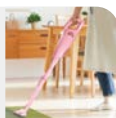

CL115FDWR1 (紅色)	* 電子開關	塵袋容量	布：500 mL 紙：330 mL
		最大氣流量	1.4 m ³ /min
CL115FDWP1 (粉紅色)	* 電子開關	連續使用 (分鐘)	強：10 中：18 標準：55
		最大密封吸力 (水柱)	5.0 kPa (510 mm H ₂ O)
		體積 (長 x 寬 x 高)	983 x 113 x 136 mm (38-3/4" x 4-7/16" x 5-3/8")
淨重 (連電池)		1.0 kg (2.2 lbs.)	
不可與其他 12V 產品共用電池			
充電器 DC1001 · 電池 · 吸嘴套件 · 窗框吸嘴 · 喉管 · 紙塵袋 · 布塵袋			

充電式吸塵機 (塵袋式)

Li-ion Ah 2.0

CL114FDWI2

備有直管緊鎖按鈕，直管不易與吸塵機鬆脫。



CL114FDWI2	* 電子開關	塵袋容量	布：500 mL 紙：330 mL
		最大氣流量	1.4 m ³ /min
CL114FDWI2	* 電子開關	連續使用 (分鐘)	強：10 中：18 標準：55
		最大密封吸力 (水柱)	5.0 kPa (510 mm H ₂ O)
		體積 (長 x 寬 x 高)	983 x 113 x 136 mm (38-3/4" x 4-7/16" x 5-3/8")
淨重 (連電池)		1.1 kg (2.4 lbs.)	
不可與其他 12V 產品共用電池			
充電器 DC1002 · 電池 · 吸嘴套件 · 窗框吸嘴 · 喉管 · 紙塵袋 · 布塵袋			

充電式吸塵機 (塵袋式)

Li-ion Ah 4.0 2.0

CL107FDZ / CL107FDZW (淨機)

備有 LED 工作燈，可在光線不足的環境下工作。



CL107FDZ (藍色)	* 電子開關	塵袋容量	布：500 mL 紙：330 mL
		最大氣流量	1.4 m ³ /min
CL107FDZW (白色)	* 電子開關	連續使用 (分鐘)	4.0 Ah： 強：20 中：24 標準：50
		最大密封吸力 (水柱)	5.0 kPa (510 mm H ₂ O)
		體積 (長 x 寬 x 高)	960 x 112 x 150 mm (37-3/4" x 4-3/8" x 5-7/8")
淨重 (連電池)		1.1 kg (2.5 lbs.)	
隨機不包括電池及充電器，需另行購買。			
吸嘴套件 · 窗框吸嘴 · 喉管 · 紙塵袋 · 布塵袋			

CL107FD 吸塵機優惠套裝

CL107FDWX1 白色 ○

CL107FDX1 藍色 ●

套裝包括：

- CL107FD主機
- 旋風式吸塵配件
- T型吸嘴
- 窗框吸嘴
- 直管
- 軟管
- 圓刷
- 高效能塵袋
- 紙塵袋
- 專用收納袋
- DC10SB 快速充電座
- BL1021B (12V, 2.0Ah) 鋰電池



家用集塵

膠囊式吸塵機安裝方法



充電式吸塵機 (塵袋式)

Li-ion Ah 2.0

CL117FDX1 / CL117FDX4 / CL117FDX7

輕便設計，三種顏色選擇！



CXT	* 電子開關	膠囊容量	650 mL
		最大氣流量	1.0 m ³ /min
		連續使用 (分鐘)	強：10 中：18 標準：55
		最大密封吸力 (水柱)	5.0 kPa (510 mm H ₂ O)
		體積 (長 x 寬 x 高)	992 x 110 x 136 mm (39" x 4-5/16" x 5-3/8")
		淨重 (連電池)	1.0 kg (2.2 lbs.)
		不可與其他 12V 產品共用電池	
		充電器 DC1002 · 電池 · 吸嘴套件 · 窗框吸嘴 · 直管 · 高效能過濾器	

充電式吸塵機 (膠囊式)

Li-ion Ah 4.0 2.0

CL106FDZ / CL106FDZW (淨機)

配合不同配件，迎合不同需要。



CXT	* 扳機開關	膠囊容量	600 mL
		最大氣流量	1.3 m ³ /min
		連續使用 (分鐘)	4.0 Ah：40
		最大密封吸力 (水柱)	3.1 kPa (316 mm H ₂ O)
		體積 (長 x 寬 x 高)	958 x 100 x 150 mm (37-3/4" x 3-15/16" x 5-7/8")
		淨重 (連電池)	1.0 kg (2.2 lbs.)
		隨機不包括電池及充電器，需另行購買。	
		吸嘴套件 · 窗框吸嘴 · 喉管 · 過濾器 (已內置) · 前過濾器 (已內置)	

充電式吸塵機 (膠囊式)

Li-ion Ah 4.0 2.0

CL108FDZ / CL108FDZW (淨機)

配合不同配件，迎合不同需要。



CXT	* 電子開關	膠囊容量	600 mL
		最大氣流量	1.2 m ³ /min
		連續使用 (分鐘)	4.0 Ah： 強：20 中：24 標準：50
		最大密封吸力 (水柱)	4.4 kPa (445 mm H ₂ O)
		體積 (長 x 寬 x 高)	956 x 110 x 150 mm (37-5/8" x 4-5/16" x 5-7/8")
		淨重 (連電池)	1.2 kg (2.7 lbs.)
		隨機不包括電池及充電器，需另行購買。	
		吸嘴套件 · 窗框吸嘴 · 喉管 · 過濾器 (已內置) · 前過濾器 (已內置)	

CL108FD 吸塵機優惠套裝

CL108FDWX3 白色 ○

CL108FDX3 藍色 ●

套裝包括：

- CL108FD主機
 - 旋風式吸塵配件
 - T型吸嘴
 - 窗框吸嘴
 - 直管
 - 軟管
 - 圓刷
 - 前過濾器
 - HEPA過濾器
 - 專用收納袋
 - DC10SB 快速充電座
 - BL1021B(12V, 2.0Ah)鋰電池
- 以上各一個



Makita®

旋風式集塵 集中垃圾易處理



可吸
乾濕垃圾



輕易清理
集塵箱的垃圾



減少消耗
吸塵袋或過濾網

短片介紹



有扣版



191D71-3(白)



191D73-9(黑)



A-70063(藍)

適用型號

CL002G, CL001G,
DCL285F, DCL284F,
DCL282, DCL281,
DCL280, CL117FD,
CL115FD, CL114FD

標準版



199491-1(白)



199553-5(黑)

適用型號

DCL182, DCL181,
DCL180, CL108FD,
CL107FD, CL106FD

集塵量 400 mL

重量 0.35 kg



簡易安裝

只需插在吸塵機與直管之間即可

附加配件

吸塵機座地架
1911L1-0

NEW

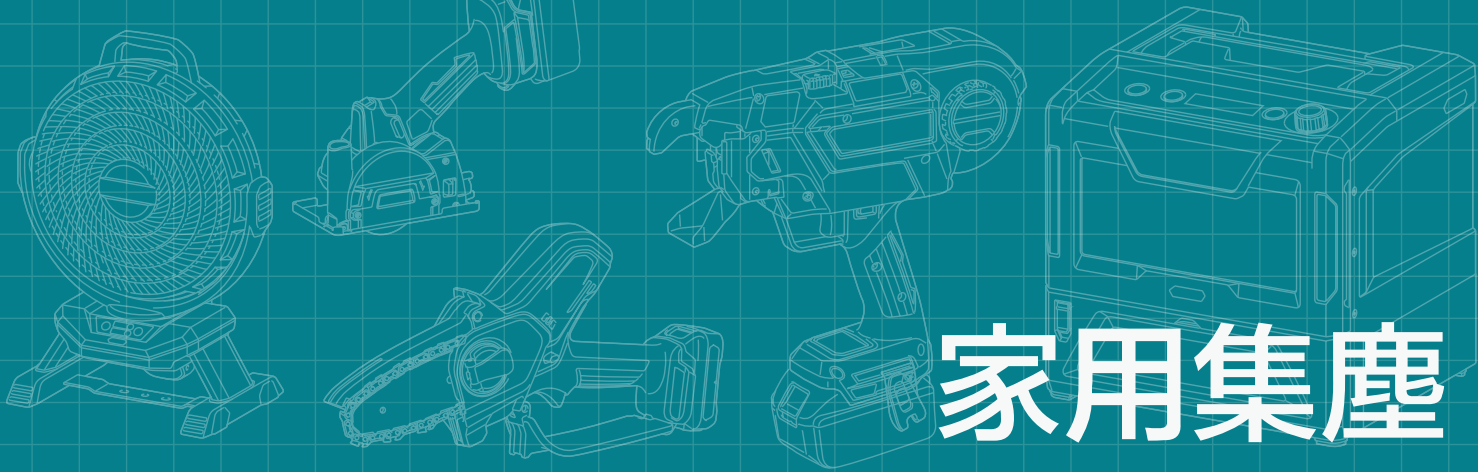

家用集塵

CL121 車用吸塵機 (吹、吸兩用)

最大氣流量

1.3 m³/min

最大密封吸力 (水柱)

4.6 kPa
(470 mmH₂O)

連續使用時間

使用BL1041B

27 / 32 / 67 min
極 / 強 / 標準

容量

布塵袋

500 mL
紙塵袋 : 330mL



充電式吸塵機 (塵袋式)

Li-ion Ah 4.0 2.0

CL121DZX1 (淨機)

備有吹風功能，可把塵埃吹在一起集中處理。

CXT

* 電子開關

塵袋容量 布：500 mL
紙：330 mL

最大氣流量 1.3 m³/min

連續使用 (分鐘) 4.0 Ah：
強：27
中：32
標準：67

最大密封吸力 (水柱) 4.6 kPa (470 mm H₂O)

體積 (長 x 寬 x 高) 359 x 138 x 202 mm
(14-1/8" x 5-7/16" x 8")

淨重 (連電池) 1.8 kg (4.0 lbs.)
隨機不包括電池及充電器，需另行購買。



刷毛吸嘴 · 地毯吸嘴 · 長吸嘴 · 軟膠吸嘴 · 吹風套件 · 紙塵袋 · 布塵袋 · 肩帶 · 工具袋

- 1 肩帶
- 2 地毯吸嘴
- 3 軟膠吸嘴
- 4 長吸嘴
- 5 刷毛吸嘴
- 6 吹風套件
- 7 紙塵袋
- 8 布塵袋

Makita

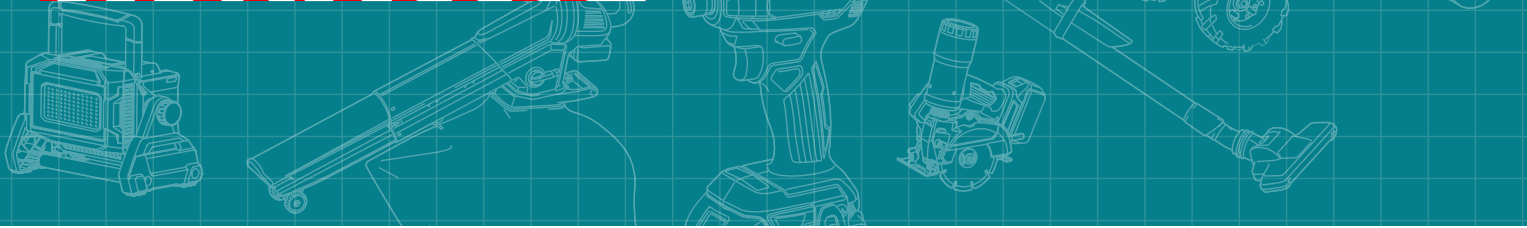

充電式風扇

Li-ion Ah 6.0 5.0 4.0 3.0 2.0 1.5

CF101DZ (淨機) 180 mm (7-1/8")

機身細小，兼可自動 45 度左右擺動。

AC 12V_{MAX}



HYBRID
XGT



扇葉直徑	180 mm (7-1/8")
最大風速	高：180 m/min 中：150 m/min 標準：120 m/min
連續使用 (小時)	4.0 Ah： 強：4.5 中：6 標準：10.5
體積 (長 x 寬 x 高)	185 x 260 x 284 mm (7-1/4" x 10-1/4" x 11-1/8")
淨重 (連電池)	1.3 kg (2.9 lbs.)

隨機不包括 AC 電源適配器、電池及充電器，需另行購買。

充電式風扇

Li-ion Ah 6.0 5.0 4.0 3.0 2.0 1.5

CF100DZ (淨機) 180 mm (7-1/8")

手柄上的活動鉤可讓風扇掛在桿上或其他可用的地方。

AC 12V_{MAX}



HYBRID
XGT



AC 電源適配器

扇葉直徑	180 mm (7-1/8")
最大風速	高：180 m/min 中：150 m/min 標準：120 m/min
連續使用 (小時)	4.0 Ah： 強：4 中：6 標準：8
體積 (長 x 寬 x 高)	149 x 260 x 252 mm (5-7/8" x 10-1/4" x 9-7/8")
淨重 (連電池)	1.3 kg (2.9 lbs.)

隨機不包括電池及充電器，需另行購買。

充電式收音機

Li-ion Ah 6.0 5.0 4.0 3.0 2.0 1.5

MR006G (淨機)

三喇叭設計，令聲音更立體悅耳！

AC 40V_{MAX} 18V
14.4V 12V_{MAX}



XGT
40V_{MAX}
Bluetooth
HYBRID



AC 電源適配器

輸出功率	40V：5 W x 2 + 25 W 18V：5 W x 2 + 25 W 12V：2 W x 2 + 10 W
頻率範圍	FM：87.5 - 108 MHz AM：522 - 1,710 kHz
連續使用 (小時)	40V 4.0 Ah：19 18V 6.0 Ah：20 12V 4.0 Ah：16
體積 (長 x 寬 x 高)	285 x 172 x 441 mm (11-1/4" x 6-3/4" x 17-3/8")
淨重 (連電池)	6.4 kg (14.1 lbs.)

隨機不包括電池及充電器，需另行購買。

充電式收音機

Li-ion Ah 6.0 5.0 4.0 3.0 2.0 1.5

MR002G (淨機)

可播放長達 27.5 小時！

AC 40V_{MAX} 18V
14.4V 12V_{MAX}



XGT
40V_{MAX}
Bluetooth
HYBRID



AC 電源適配器

輸出功率	40V：5 W x 2 18V：3.5 W x 2 12V / AC：1.2 W x 2
頻率範圍	FM：87.5 - 108 MHz AM：522 - 1,710 kHz
連續使用 (小時)	40V 4.0 Ah：27.5 18V 6.0 Ah：22 12V 4.0 Ah：18.5
體積 (長 x 寬 x 高)	280 x 171 x 434 mm (11" x 6-3/4" x 17-1/8")
淨重 (連電池)	5.3 kg (11.7 lbs.)

隨機不包括電池及充電器，需另行購買。

充電式收音機

Li-ion Ah 6.0 5.0 4.0 3.0 2.0 1.5

DMR300 (淨機)

使用 AC 電源時可為插入的電池充電。

AC 18V 14.4V
12V_{MAX}



Bluetooth



AC 電源適配器

輸出功率	18V：3.5 W x 2 14.4V：2.2 W x 2 12V：1.2 W x 2
頻率範圍	FM：87.5 - 108 MHz AM：522 - 1,710 kHz
連續使用 (小時)	18V 6.0 Ah：24
體積 (長 x 寬 x 高)	268 x 185 x 427 mm (10-1/2" x 7-1/4" x 16-3/4")
淨重 (連電池)	6.6 kg (14.6 lbs.)

隨機不包括電池及充電器，需另行購買。

DMR300 充電功能資料

電池充電功能

- 當收音機使用 AC 電源時，可同時為插入的鋰電池充電。
 - 電池充電時，可繼續享受音樂
- 充電時間(分鐘)：

12Vmax		
BL1021B (2.0Ah)	BL1041B (4.0Ah)	
40	75	
18V		
BL1820B (2.0Ah)	BL1850B (5.0Ah)	BL1860B (6.0Ah)
38	84	100

充電情況顯示

- LCD 顯示屏顯示：
充電中、充電完成、準備充電、充電錯誤
- 顯示電池已充滿 85%

指示燈顯示方式	充電中電量的情況
(閃爍)	電量少於 80%
(閃爍)	電量多於 80%
(長亮)	已完成充電

家居·休閒用品

充電式揚聲器

Li-ion Ah 6.0 5.0 4.0 3.0 2.0 1.5

DMR203 / DMR203B

一部手機可同時配對 10 部揚聲器同步使用！

AC 18V 14.4V
12V_{MAX}



Bluetooth
HYBRID

輸出功率 18V : 10 W
14.4V : 6 W
12V : 3.5 W
AC : 3.5 W

頻率範圍 藍芽版本 : 5.0
最大可接收範圍 : 10 m

連續使用 (小時) 18V 6.0 Ah : 32
12V 4.0 Ah : 20

體積 (長 x 寬 x 高) 217 x 203 x 286 mm
(8-1/2" x 8" x 11-1/4")

淨重 (連電池) 3.4 kg (7.5 lbs.)
隨機不包括電池及充電器，需另行購買。



DMR203

DMR203B



AC 電源適配器

充電式揚聲器

Li-ion Ah 6.0 5.0 4.0 3.0 2.0 1.5

DMR202 / DMR202B

可直接插入 USB 記憶體播放樂曲。

AC 18V 14.4V
12V_{MAX}



Bluetooth
HYBRID

輸出功率 18V : 10 W
14.4V : 6 W
12V : 3 W
AC : 3 W

頻率範圍 藍芽版本 : 4.0
最大可接收範圍 : 10 m

USB 文件格式 MP3 / WMA / AAC

連續使用 (小時) 18V 6.0 Ah : 32
12V 4.0 Ah : 20

體積 (長 x 寬 x 高) 211 x 203 x 286 mm
(8-5/16" x 8" x 11-1/4")

淨重 (連電池) 3.3 kg (7.3 lbs.)
隨機不包括電池及充電器，需另行購買。



DMR202

DMR202B



AC 電源適配器

充電式揚聲器

Li-ion Ah 6.0 5.0 4.0 3.0 2.0 1.5

DMR200 / DMR200B

配備藍芽功能，可由 AC 電源或鋰電池驅動。

AC 18V 14.4V
12V_{MAX}



Bluetooth
HYBRID

輸出功率 18V : 10 W
14.4V : 6 W
12V : 3.5 W
AC : 4 W

頻率範圍 藍芽版本 : 4.0
最大可接收範圍 : 10 m

連續使用 (小時) 18V 6.0 Ah : 37
12V 4.0 Ah : 28

體積 (長 x 寬 x 高) 211 x 203 x 286 mm
(8-5/16" x 8" x 11-1/4")

淨重 (連電池) 3.3 kg (7.2 lbs.)
隨機不包括電池及充電器，需另行購買。



DMR200

DMR200B



AC 電源適配器

充電式揚聲器 DMR203



充電式揚聲器

Li-ion Ah 6.0 5.0 4.0 3.0 2.0 1.5

DMR114 (淨機)

三喇叭設計，令聲音更立體悅耳！

AC 18V 14.4V
12V_{MAX}



Bluetooth
HYBRID

輸出功率 18V : 5 W x 2 + 25 W
14.4V : 3 W x 2 + 15 W
12V : 2 W x 2 + 10 W

頻率範圍 藍芽版本 : 5.0
最大可接收範圍 : 10 m

連續使用 (小時) 18V 6.0 Ah : 21
12V 4.0 Ah : 16

體積 (長 x 寬 x 高) 268 x 164 x 437 mm
(11-1/4" x 6-3/4" x 17-3/8")

淨重 (連電池) 5.6 kg (12.3 lbs.)
隨機不包括電池及充電器，需另行購買。



AC 電源適配器

充電式收音機

Li-ion Ah 6.0 5.0 4.0 3.0 2.0 1.5 1.3 1.0

DMR108 / DMR108B (淨機)

配備藍芽功能，可由 AC 電源或鋰電池驅動。

AC 18V 14.4V
12V_{MAX} 10.8V 7.2V



Bluetooth
HYBRID

輸出功率 18V : 3.5 W x 2
14.4V : 2.2 W x 2
12V / 10.8V : 1.2 W x 2

頻率範圍 FM : 87.5 - 108 MHz
AM : 522 - 1,710 kHz

連續使用 (小時) 18V 6.0 Ah : 40
12V 4.0 Ah : 25

體積 (長 x 寬 x 高) 262 x 163 x 431 mm
(10-3/8" x 6-3/8" x 17")

淨重 (連電池) 4.4 kg (9.7 lbs.)
隨機不包括電池及充電器，需另行購買。



AC 電源適配器

Makita



充電式 LED 手電筒

Li-ion Ah 4.0 2.0

ML107

3 種模式：全發光 LED 模式 / 側發光 LED 模式 / 頂發光 LED 模式。

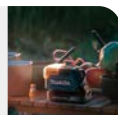

光通量	全發光 LED 模式：200 lm 側發光 LED 模式：100 lm 頂發光 LED 模式：100 lm
照度 (距離光源 0.5 米)	全發光 LED 模式：175 lx 側發光 LED 模式：130 lx 頂發光 LED 模式：130 lx
連續使用 (小時)	4.0 Ah： 全發光 LED 模式：17 側發光 LED 模式：29 頂發光 LED 模式：29

體積 (長 x 寬 x 高) 92 x 54 x 47 mm
(3-5/8" x 2-1/8" x 1-7/8")

淨重 (連電池) 0.34 kg (0.75 lbs.)

隨機不包括電池及充電器，需另行購買。

充電式 LED 手電筒

Li-ion Ah 4.0 2.0

ML103

LED 手電筒細小輕巧，方便攜帶。

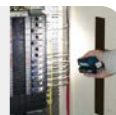

光通量 100 lm

照度 (距離光源 0.5 米) 240 lx

連續使用 (小時) 4.0 Ah：28
2.0 Ah：14

體積 (長 x 寬 x 高) 87 x 64 x 54 mm
(3-7/16" x 2-1/2" x 2-1/8")

淨重 (連電池) 0.28 kg (0.6 lbs.)

隨機不包括電池及充電器，需另行購買。

充電式手電筒

Li-ion Ah 4.0 2.0

ML104

備有 USB 插位，可供使用 USB 電源線的產品充電。



光通量	提燈模式： 360°：710 lm；90°：190 lm 電筒模式：130 lm
照度 (距離光源 0.5 米)	提燈模式： 360°：340 lx；90°：190 lx 電筒模式：1,900 lx
連續使用 (小時)	4.0 Ah： 提燈模式： 強：5.5；標準：17 電筒模式：19

體積 (長 x 寬 x 高) 394 x 66 x 132 mm
(15-1/2" x 2-5/8" x 5-3/16")

淨重 (連電池) 0.61 kg (1.4 lbs.)

隨機不包括電池及充電器，需另行購買。

12V 工作燈專用配件

GM00001714



零件編號

名稱

適用型號

GM00001714

磁石

ML104, ML105, ML106

充電式手電筒

Li-ion Ah 4.0 2.0

ML105

能持續使用長達 14 小時。



光通量 190 lm

照度 (距離光源 1 米) 500 lx

連續使用 (小時) 4.0 Ah：14
2.0 Ah：7

體積 (長 x 寬 x 高) 249 x 66 x 93 mm
(9-3/4" x 2-5/8" x 3-5/8")

淨重 (連電池) 0.53 kg (1.2 lbs.)

隨機不包括電池及充電器，需另行購買。

充電式手電筒

Li-ion Ah 4.0 2.0

ML106

可調較 LED 燈聚焦度，能變更照明強度和範圍。

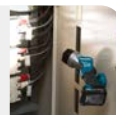

光通量 190 lm

照度 (距離光源 1 米) 500 lx

連續使用 (小時) 4.0 Ah：12

體積 (長 x 寬 x 高) 290 x 66 x 93 mm
(11-3/8" x 2-5/8" x 3-5/8")

淨重 (連電池) 0.78 kg (1.7 lbs.)

隨機不包括電池及充電器，需另行購買。

家居·休閒用品

充電式小型氣泵

Li-ion Ah 4.0 | 2.0

MP100DZ (淨機)

可為車胎、球類及其他充氣用品充氣。



最大氣壓	830 kPa (121 PSI) [8.3 bar]
排氣量	200 kPa : 10 L/min
喉管長度	65 cm (25-1/2")
體積 (長 x 寬 x 高)	255 x 74 x 173 mm (10" x 2-15/16" x 6-13/16")
淨重 (連電池)	1.3 kg (3.0 lbs.)



英嘴·法嘴·針嘴·錐形嘴

隨機不包括電池及充電器，需另行購買。



充電式小型氣泵 MP100D

充電式咖啡機 DCM501



充電式咖啡機

Li-ion Ah 6.0 | 5.0 | 4.0 | 3.0 | 2.0 | 1.5

DCM501Z / DCM501ZAR

攜帶到不同地方也可品嚐美味的咖啡。

18V 12V_{MAX}



DCM501ZAR

DCM501Z

沖調杯數 (130 mL / 杯)	18V 6.0 Ah : 5 12V 4.0 Ah : 2
體積 (長 x 寬 x 高)	243 x 187 x 218 mm (9-9/16" x 7-3/8" x 8-9/16")
淨重 (連電池)	1.9 kg (4.1 lbs.)



隨機不包括電池及充電器，需另行購買。

USB 適配器

Li-ion Ah 4.0 | 2.0

ADP06 / ADP08

備有開關掣，可於使用時才開啟。



USB 插口	1 個 (A 型)
輸出電壓 (每個插口)	5 V
輸出電流	2.1 A
體積 (長 x 寬 x 高)	80 x 53 x 38 mm (3-1/8" x 2-1/16" x 1-1/2")
淨重 (連電池)	4.0 Ah : 0.44 kg (1.0 lbs.)

隨機不包括電池，需另行購買。

充電式多用途電剪刀

Li-ion Ah 4.0 | 2.0

CP100DSA / CP100DZ (淨機)

可切割地毯、帆布、布料、紙、索帶、橡膠、軟膠片。



CP100DSA CP100DZ



刀片

最大切割能力	6mm (1/4")
回轉數 (rpm)	300
體積 (長 x 寬 x 高)	291 x 66 x 121 mm (11-1/2" x 2-5/8" x 4-3/4")
淨重 (連電池)	0.92 kg (2.0 lbs.)









CP100DSA : 快速充電器 (DC10SB) 及 2.0Ah 電池 1 顆
CP100DZ : 隨機不包括電池、充電器及攜帶箱，需另行購買

充電式風扇外套

風扇種類	連續使用時間 (小時)	洗水	雙層構造	特點																									
DFV215A	 18V 适配器  <table border="1"> <tr> <td></td> <td>4</td> <td>3</td> <td>2</td> <td>1</td> </tr> <tr> <td>6.0Ah:</td> <td>15.5</td> <td>25</td> <td>43</td> <td>58.5</td> </tr> <tr> <td>5.0Ah:</td> <td>13</td> <td>21</td> <td>36</td> <td>49</td> </tr> <tr> <td>4.0Ah:</td> <td>10.5</td> <td>16.5</td> <td>28.5</td> <td>39</td> </tr> <tr> <td>2.0Ah:</td> <td>5</td> <td>8</td> <td>14</td> <td>17.5</td> </tr> </table>		4	3	2	1	6.0Ah:	15.5	25	43	58.5	5.0Ah:	13	21	36	49	4.0Ah:	10.5	16.5	28.5	39	2.0Ah:	5	8	14	17.5	✓	✓	仿牛仔布 抗菌除臭
	4	3	2	1																									
6.0Ah:	15.5	25	43	58.5																									
5.0Ah:	13	21	36	49																									
4.0Ah:	10.5	16.5	28.5	39																									
2.0Ah:	5	8	14	17.5																									
DFV214A	 18V 适配器  + TD00000111	✓	✓	前扣式																									
DFV210A	雙風扇 	✓	✓	可調校 鬆緊																									
DFJ416A (有肩墊)	 最大風量： 2.7m ³ /min  NEW 專用電池 BL1055B	✓	✓	可拆袖 防UV																									
DFJ312A	 12Vmax 适配器  + TD00000110	✓	✓	棉質 可拆袖																									
DFJ216A		✓		保冷劑 口袋																									
DFJ214Z	雙風扇 	✓	✓	反光帶																									
DFJ213Z	 最大風量： 2.2m ³ /min  12Vmax 适配器  +	✓	✓	耐伸縮																									
DFJ212Z	 12Vmax 适配器  +	✓	✓	有帽																									

購買時請註明需要哪種電壓的電池座。 外套不包括電池及充電器，需另行購買。

尺寸參考表

DFV210A	DFV214A	DFV215A																																																																																										
 <table border="1"> <tr> <th>尺寸</th> <th>高度(cm)</th> <th>肩寬(cm)</th> <th>袖長(cm)</th> <th>胸圍(cm)</th> <th>腰圍(cm)</th> </tr> <tr> <td>A</td> <td>B</td> <td>C</td> <td>D</td> <td>E</td> <td></td> </tr> <tr> <td>M</td> <td>65</td> <td>41</td> <td>-</td> <td>111</td> <td>105</td> </tr> <tr> <td>L</td> <td>67</td> <td>43</td> <td>-</td> <td>116</td> <td>110</td> </tr> <tr> <td>XL</td> <td>69</td> <td>45</td> <td>-</td> <td>121</td> <td>115</td> </tr> </table>	尺寸	高度(cm)	肩寬(cm)	袖長(cm)	胸圍(cm)	腰圍(cm)	A	B	C	D	E		M	65	41	-	111	105	L	67	43	-	116	110	XL	69	45	-	121	115	 <table border="1"> <tr> <th>尺寸</th> <th>高度(cm)</th> <th>肩寬(cm)</th> <th>袖長(cm)</th> <th>胸圍(cm)</th> <th>腰圍(cm)</th> </tr> <tr> <td>A</td> <td>B</td> <td>C</td> <td>D</td> <td>E</td> <td></td> </tr> <tr> <td>FA(S-L)</td> <td>49</td> <td>39</td> <td>-</td> <td>103-122</td> <td>98-117</td> </tr> <tr> <td>FB(XL-3XL)</td> <td>55</td> <td>42</td> <td>-</td> <td>112-131</td> <td>107-126</td> </tr> </table>	尺寸	高度(cm)	肩寬(cm)	袖長(cm)	胸圍(cm)	腰圍(cm)	A	B	C	D	E		FA(S-L)	49	39	-	103-122	98-117	FB(XL-3XL)	55	42	-	112-131	107-126	 <table border="1"> <tr> <th>尺寸</th> <th>高度(cm)</th> <th>肩寬(cm)</th> <th>袖長(cm)</th> <th>胸圍(cm)</th> <th>腰圍(cm)</th> </tr> <tr> <td>A</td> <td>B</td> <td>C</td> <td>D</td> <td>E</td> <td></td> </tr> <tr> <td>02</td> <td>65</td> <td>41</td> <td>-</td> <td>111</td> <td>105</td> </tr> <tr> <td>03</td> <td>67</td> <td>43</td> <td>-</td> <td>116</td> <td>110</td> </tr> <tr> <td>04</td> <td>69</td> <td>45</td> <td>-</td> <td>121</td> <td>115</td> </tr> </table>	尺寸	高度(cm)	肩寬(cm)	袖長(cm)	胸圍(cm)	腰圍(cm)	A	B	C	D	E		02	65	41	-	111	105	03	67	43	-	116	110	04	69	45	-	121	115						
尺寸	高度(cm)	肩寬(cm)	袖長(cm)	胸圍(cm)	腰圍(cm)																																																																																							
A	B	C	D	E																																																																																								
M	65	41	-	111	105																																																																																							
L	67	43	-	116	110																																																																																							
XL	69	45	-	121	115																																																																																							
尺寸	高度(cm)	肩寬(cm)	袖長(cm)	胸圍(cm)	腰圍(cm)																																																																																							
A	B	C	D	E																																																																																								
FA(S-L)	49	39	-	103-122	98-117																																																																																							
FB(XL-3XL)	55	42	-	112-131	107-126																																																																																							
尺寸	高度(cm)	肩寬(cm)	袖長(cm)	胸圍(cm)	腰圍(cm)																																																																																							
A	B	C	D	E																																																																																								
02	65	41	-	111	105																																																																																							
03	67	43	-	116	110																																																																																							
04	69	45	-	121	115																																																																																							
 <table border="1"> <tr> <th>尺寸</th> <th>高度(cm)</th> <th>肩寬(cm)</th> <th>袖長(cm)</th> <th>胸圍(cm)</th> <th>腰圍(cm)</th> </tr> <tr> <td>A</td> <td>B</td> <td>C</td> <td>D</td> <td>E</td> <td></td> </tr> <tr> <td>M</td> <td>65</td> <td>45</td> <td>60</td> <td>116</td> <td>86-110</td> </tr> <tr> <td>L</td> <td>67</td> <td>47</td> <td>62</td> <td>121</td> <td>91-115</td> </tr> <tr> <td>XL</td> <td>69</td> <td>49</td> <td>64</td> <td>126</td> <td>96-120</td> </tr> </table>	尺寸	高度(cm)	肩寬(cm)	袖長(cm)	胸圍(cm)	腰圍(cm)	A	B	C	D	E		M	65	45	60	116	86-110	L	67	47	62	121	91-115	XL	69	49	64	126	96-120	 <table border="1"> <tr> <th>尺寸</th> <th>高度(cm)</th> <th>肩寬(cm)</th> <th>袖長(cm)</th> <th>胸圍(cm)</th> <th>腰圍(cm)</th> </tr> <tr> <td>A</td> <td>B</td> <td>C</td> <td>D</td> <td>E</td> <td></td> </tr> <tr> <td>M</td> <td>63</td> <td>45</td> <td>60</td> <td>116</td> <td>95-105</td> </tr> <tr> <td>L</td> <td>65</td> <td>47</td> <td>62</td> <td>121</td> <td>100-110</td> </tr> <tr> <td>XL</td> <td>67</td> <td>49</td> <td>64</td> <td>126</td> <td>105-115</td> </tr> </table>	尺寸	高度(cm)	肩寬(cm)	袖長(cm)	胸圍(cm)	腰圍(cm)	A	B	C	D	E		M	63	45	60	116	95-105	L	65	47	62	121	100-110	XL	67	49	64	126	105-115	 <table border="1"> <tr> <th>尺寸</th> <th>高度(cm)</th> <th>肩寬(cm)</th> <th>袖長(cm)</th> <th>胸圍(cm)</th> <th>腰圍(cm)</th> </tr> <tr> <td>A</td> <td>B</td> <td>C</td> <td>D</td> <td>E</td> <td></td> </tr> <tr> <td>M</td> <td>63</td> <td>45</td> <td>60</td> <td>116</td> <td>100-110</td> </tr> <tr> <td>L</td> <td>65</td> <td>47</td> <td>62</td> <td>121</td> <td>105-115</td> </tr> <tr> <td>XL</td> <td>67</td> <td>49</td> <td>64</td> <td>126</td> <td>110-120</td> </tr> </table>	尺寸	高度(cm)	肩寬(cm)	袖長(cm)	胸圍(cm)	腰圍(cm)	A	B	C	D	E		M	63	45	60	116	100-110	L	65	47	62	121	105-115	XL	67	49	64	126	110-120
尺寸	高度(cm)	肩寬(cm)	袖長(cm)	胸圍(cm)	腰圍(cm)																																																																																							
A	B	C	D	E																																																																																								
M	65	45	60	116	86-110																																																																																							
L	67	47	62	121	91-115																																																																																							
XL	69	49	64	126	96-120																																																																																							
尺寸	高度(cm)	肩寬(cm)	袖長(cm)	胸圍(cm)	腰圍(cm)																																																																																							
A	B	C	D	E																																																																																								
M	63	45	60	116	95-105																																																																																							
L	65	47	62	121	100-110																																																																																							
XL	67	49	64	126	105-115																																																																																							
尺寸	高度(cm)	肩寬(cm)	袖長(cm)	胸圍(cm)	腰圍(cm)																																																																																							
A	B	C	D	E																																																																																								
M	63	45	60	116	100-110																																																																																							
L	65	47	62	121	105-115																																																																																							
XL	67	49	64	126	110-120																																																																																							
 <table border="1"> <tr> <th>尺寸</th> <th>高度(cm)</th> <th>肩寬(cm)</th> <th>袖長(cm)</th> <th>胸圍(cm)</th> <th>腰圍(cm)</th> </tr> <tr> <td>A</td> <td>B</td> <td>C</td> <td>D</td> <td>E</td> <td></td> </tr> <tr> <td>M</td> <td>64</td> <td>42</td> <td>82</td> <td>113</td> <td>107</td> </tr> <tr> <td>L</td> <td>66</td> <td>44</td> <td>85</td> <td>118</td> <td>112</td> </tr> <tr> <td>XL</td> <td>68</td> <td>46</td> <td>88</td> <td>123</td> <td>117</td> </tr> </table>	尺寸	高度(cm)	肩寬(cm)	袖長(cm)	胸圍(cm)	腰圍(cm)	A	B	C	D	E		M	64	42	82	113	107	L	66	44	85	118	112	XL	68	46	88	123	117	 <table border="1"> <tr> <th>尺寸</th> <th>高度(cm)</th> <th>肩寬(cm)</th> <th>袖長(cm)</th> <th>胸圍(cm)</th> <th>腰圍(cm)</th> </tr> <tr> <td>A</td> <td>B</td> <td>C</td> <td>D</td> <td>E</td> <td></td> </tr> <tr> <td>M</td> <td>63</td> <td>45</td> <td>60</td> <td>114</td> <td>100-108</td> </tr> <tr> <td>L</td> <td>65</td> <td>47</td> <td>62</td> <td>119</td> <td>105-113</td> </tr> <tr> <td>XL</td> <td>67</td> <td>49</td> <td>64</td> <td>124</td> <td>110-118</td> </tr> </table>	尺寸	高度(cm)	肩寬(cm)	袖長(cm)	胸圍(cm)	腰圍(cm)	A	B	C	D	E		M	63	45	60	114	100-108	L	65	47	62	119	105-113	XL	67	49	64	124	110-118	 <table border="1"> <tr> <th>尺寸</th> <th>高度(cm)</th> <th>肩寬(cm)</th> <th>袖長(cm)</th> <th>胸圍(cm)</th> <th>腰圍(cm)</th> </tr> <tr> <td>A</td> <td>B</td> <td>C</td> <td>D</td> <td>E</td> <td></td> </tr> <tr> <td>M</td> <td>66</td> <td>45</td> <td>60</td> <td>114</td> <td>100-108</td> </tr> <tr> <td>L</td> <td>68</td> <td>47</td> <td>62</td> <td>119</td> <td>105-113</td> </tr> <tr> <td>XL</td> <td>70</td> <td>49</td> <td>64</td> <td>124</td> <td>110-118</td> </tr> </table>	尺寸	高度(cm)	肩寬(cm)	袖長(cm)	胸圍(cm)	腰圍(cm)	A	B	C	D	E		M	66	45	60	114	100-108	L	68	47	62	119	105-113	XL	70	49	64	124	110-118
尺寸	高度(cm)	肩寬(cm)	袖長(cm)	胸圍(cm)	腰圍(cm)																																																																																							
A	B	C	D	E																																																																																								
M	64	42	82	113	107																																																																																							
L	66	44	85	118	112																																																																																							
XL	68	46	88	123	117																																																																																							
尺寸	高度(cm)	肩寬(cm)	袖長(cm)	胸圍(cm)	腰圍(cm)																																																																																							
A	B	C	D	E																																																																																								
M	63	45	60	114	100-108																																																																																							
L	65	47	62	119	105-113																																																																																							
XL	67	49	64	124	110-118																																																																																							
尺寸	高度(cm)	肩寬(cm)	袖長(cm)	胸圍(cm)	腰圍(cm)																																																																																							
A	B	C	D	E																																																																																								
M	66	45	60	114	100-108																																																																																							
L	68	47	62	119	105-113																																																																																							
XL	70	49	64	124	110-118																																																																																							

尺寸僅供參考，歡迎客戶到牧田陳列室試穿。

充電式發熱衣 及發熱氈

充電式發熱上衣 DCX201

NEW



衣領拉鏈設計



4組發熱器

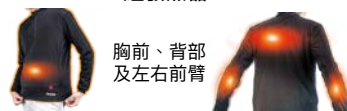

胸前、背部
及左右前臂

充電式發熱外衣 DCJ205Y



外衣表面採用防水物料



5組發熱器

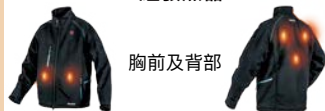

胸前及背部

充電式發熱背心 DCV202Y



手機口袋
以適配器為手機充電
時，可存放在此

4組發熱器

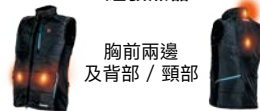

胸前兩邊
及背部 / 頸部

充電式發熱氈

DCB200AX1 (黑)
DCB200BX1 (啡)

尺寸 700 x 1400 mm



專用電池 BL1055B



USB-C插口
可為流動裝置充電

NEW

型號	轉接線	可使用電池種類	連續使用時間(小時)																
充電式發熱上衣 DCX201	轉接線 TD00000112	NEW 專用電池 BL1055B 18V 適配器 TD00000111 + 18V 電池 12V 適配器 TD00000110 + 12V 電池	<table border="1"> <thead> <tr> <th></th> <th>高</th> <th>中</th> <th>標準</th> </tr> </thead> <tbody> <tr> <td>BL1055B</td> <td>5.5</td> <td>11</td> <td>20</td> </tr> <tr> <td>18V 6.0Ah</td> <td>7.5</td> <td>16</td> <td>33</td> </tr> <tr> <td>12V 4.0Ah</td> <td>3.5</td> <td>7</td> <td>15</td> </tr> </tbody> </table>		高	中	標準	BL1055B	5.5	11	20	18V 6.0Ah	7.5	16	33	12V 4.0Ah	3.5	7	15
			高	中	標準														
BL1055B			5.5	11	20														
18V 6.0Ah			7.5	16	33														
12V 4.0Ah	3.5	7	15																
充電式發熱背心 DCV202Y	<table border="1"> <thead> <tr> <th></th> <th>高</th> <th>中</th> <th>標準</th> </tr> </thead> <tbody> <tr> <td>BL1055B</td> <td>4</td> <td>7</td> <td>20</td> </tr> <tr> <td>18V 6.0Ah</td> <td>10</td> <td>20</td> <td>35</td> </tr> <tr> <td>12V 4.0Ah</td> <td>4.0</td> <td>7.5</td> <td>14</td> </tr> </tbody> </table>		高	中	標準	BL1055B	4	7	20	18V 6.0Ah	10	20	35	12V 4.0Ah	4.0	7.5	14		
	高	中	標準																
BL1055B	4	7	20																
18V 6.0Ah	10	20	35																
12V 4.0Ah	4.0	7.5	14																
充電式發熱外衣 DCJ205Y	<table border="1"> <thead> <tr> <th></th> <th>高</th> <th>中</th> <th>標準</th> </tr> </thead> <tbody> <tr> <td>BL1055B</td> <td>4</td> <td>7</td> <td>20</td> </tr> <tr> <td>18V 6.0Ah</td> <td>8.5</td> <td>14</td> <td>35</td> </tr> <tr> <td>12V 4.0Ah</td> <td>3.5</td> <td>5.5</td> <td>14</td> </tr> </tbody> </table>		高	中	標準	BL1055B	4	7	20	18V 6.0Ah	8.5	14	35	12V 4.0Ah	3.5	5.5	14		
	高	中	標準																
BL1055B	4	7	20																
18V 6.0Ah	8.5	14	35																
12V 4.0Ah	3.5	5.5	14																
充電式發熱氈 DCB200A/DCB200BX1	<table border="1"> <thead> <tr> <th></th> <th>高</th> <th>中</th> <th>標準</th> </tr> </thead> <tbody> <tr> <td>BL1055B</td> <td>4</td> <td>7</td> <td>20</td> </tr> <tr> <td>18V 6.0Ah</td> <td>10</td> <td>20</td> <td>35</td> </tr> <tr> <td>12V 4.0Ah</td> <td>4.0</td> <td>7.5</td> <td>14</td> </tr> </tbody> </table>		高	中	標準	BL1055B	4	7	20	18V 6.0Ah	10	20	35	12V 4.0Ah	4.0	7.5	14		
	高	中	標準																
BL1055B	4	7	20																
18V 6.0Ah	10	20	35																
12V 4.0Ah	4.0	7.5	14																

購買時請註明需要哪種電壓的電池座。
不包括電池及充電器，需另行購買。

尺寸參考表



DCX201

尺寸	高度(cm)	肩寬(cm)	袖長(cm)	胸圍(cm)	腰圍(cm)
	A	B	C	D	E
M	65	46.5	60	53	52
L	68	48.5	61	56	55
XL	71	51.5	62	59	58

DCJ205

尺寸	高度(cm)	肩寬(cm)	袖長(cm)	胸圍(cm)	腰圍(cm)
	A	B	C	D	E
S	68	50.5	63	108	102
M	69	52.5	64.5	118	112
L	71	54.5	66	128	122
XL	75	55.5	67	138	132

DCV202

尺寸	高度(cm)	肩寬(cm)	胸圍(cm)	腰圍(cm)
	A	B	C	D
S	72	47.5	114	116
M	73	49.5	120	122
L	74	51.5	126	128
XL	75	53.5	132	134

尺寸僅供參考，歡迎客戶到牧田陳列室試穿。

註冊商標

Makita[®]

maktec[®]
by Makita

Makita[®]

maktec[®]

牧田[®]

牧科[®]



Makita[®]
amt

上述商標已經在香港特區政府香港生產力促進局轄下的知識產權服務中心辦理註冊專利。對於任何侵犯上述商標專用權之行為，包括未經許可製造、批發或零售附有上述商標之電動工具及配件，本公司必定追究法律責任。

客戶可透過Facebook, Instagram
及WhatsApp 與牧田緊密溝通

 Makita HK

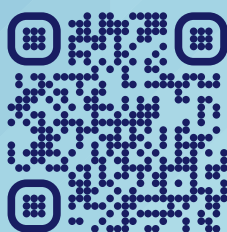

 makita.com.hk

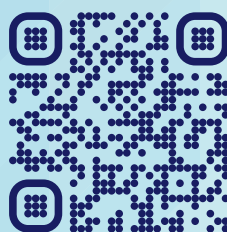

 Makita HK

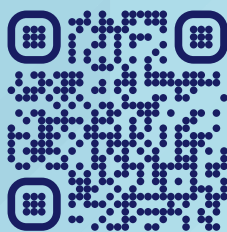

 6999 3828

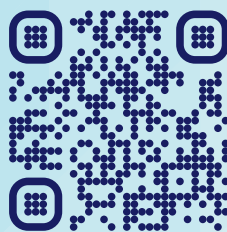

牧田陳列室 牧田澳門服務中心 流動示範服務



九龍旺角新填地街373號
(山東街口·香港康得思酒店斜對面)
電話: +852 2648-8633



澳門和隆街11號和隆閣地下A室
(荷蘭園正街行人天橋附近)
電話: +853 2835-4587



流動示範服務專線
電話: +852 5193-8850

牧田(香港)有限公司

香港新界沙田安平街8號偉達中心3樓

電話: (852) 2648 8734 傳真: (852) 2648 5237

 6999 3828

  Makita HK

 makita.com.hk