

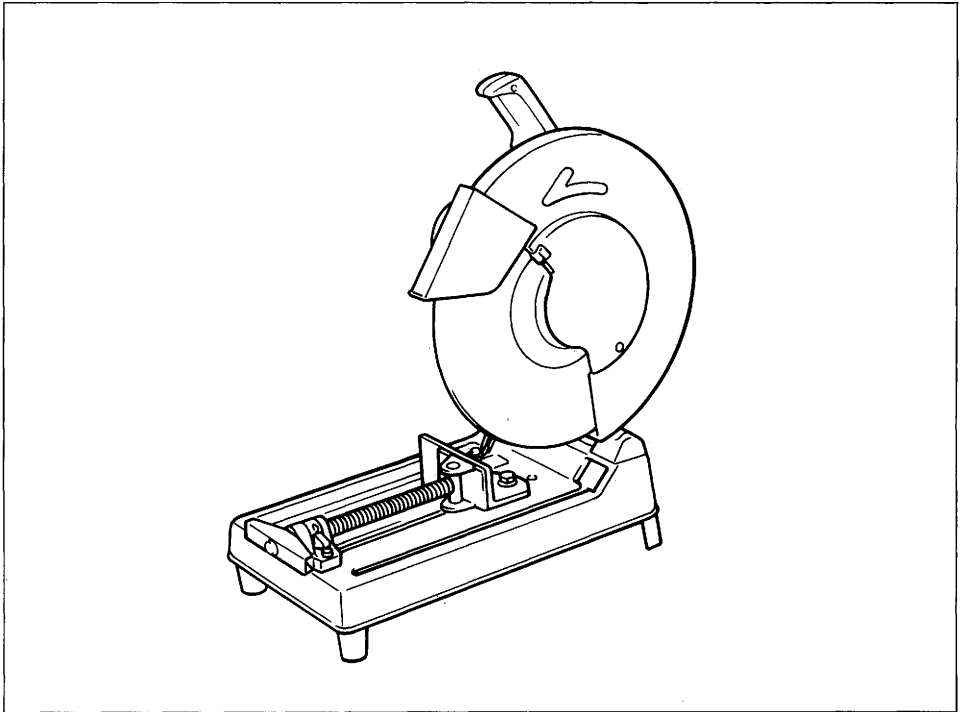

# Portable Cut-Off

**305 mm (12'')** MODEL 2412N  
**355 mm (14'')** MODEL 2414

## INSTRUCTION MANUAL



### SPECIFICATIONS

Model	Blade diameter	Hole diameter	No load speed (RPM)	Dimensions (L x W x H)	Net weight
2412N	305 mm (12'')	25.4 mm (1'')	3,800	490 mm x 260 mm x 550 mm (19-1/4'' x 10-1/4'' x 21-5/8'')	15.0 kg (33 lbs)
2414	355 mm (14'')	25.4 mm (1'')	3,800	500 mm x 280 mm x 600 mm (19-11/16'' x 11'' x 23-5/8'')	16.3 kg (36 lbs)

\* Manufacturer reserves the right to change specifications without notice.

\* Note: Specifications may differ from country to country.

## **SAFETY INSTRUCTIONS**

**Warning!** When using electric machines, basic safety precautions should always be followed to reduce the risk of fire, electric shock and personal injury, including the following.

Read all these instructions before attempting to operate this product and save these instructions.

For safe operation:

1. **Keep work area clean**  
Cluttered areas and benches invite injuries.
2. **Consider work area environment**  
Don't expose power machines to rain. Don't use power machines in damp or wet locations. Keep work area well lit. Don't use power machines in presence of flammable liquids or gases.
3. **Guard against electric shock**  
Prevent body contact with grounded surfaces (e. g. pipes, radiators, ranges refrigerators).
4. **Keep children away**  
Do not let visitors contact machine or extension cord. All visitors should be kept away from work area.
5. **Store idle machines**  
When not in use, machines should be stored in dry, high, or locked-up place, out of the reach of children.
6. **Don't force machine**  
It will do the job better and safer at the rate for which it was intended.
7. **Use right machine**  
Don't force small machines or attachments to do the job of a heavy duty machine. Don't use machines for purposes not intended; for example, don't use circular saw for cutting tree limbs or logs.
8. **Dress properly**  
Do not wear loose clothing or jewelry. They can be caught in moving parts. Rubber gloves and non-skid footwear are recommended when working outdoors. Wear protective hair covering to contain long hair.
9. **Use safety glasses**  
Also use face or dust mask if cutting operation is dusty.
10. **Connect dust extraction equipment**  
If devices are provided for the connection of dust extraction and collection facilities, ensure these are connected and properly used.
11. **Don't abuse cord**  
Never carry machine by cord or yank it to disconnect it from receptacle. Keep cord from heat, oil and sharp edges.
12. **Secure work**  
Use clamps or a vise to hold work. It's safer than using your hand and it frees both hands to operate machine.

13. **Don't overreach**  
Keep proper footing and balance at all times.
14. **Maintain machines with care**  
Keep machines sharp and clean for better and safer performance. Follow instructions for lubricating and changing accessories. Inspect machine cords periodically and, if damaged, have repaired by authorized service facility. Inspect extension cords periodically and replace if damaged. Keep handles dry, clean and free from oil and grease.
15. **Disconnect machines**  
When not in use, before servicing, and when changing accessories such as blades, bits and cutters.
16. **Remove adjusting keys and wrenches**  
Form the habit of checking to see that keys and adjusting wrenches are removed from machine before turning it on.
17. **Avoid unintentional starting**  
Don't carry plugged-in machine with finger on switch. Be sure switch is off when plugging in.
18. **Outdoor use extension cords**  
When machine is used outdoors, use only extension cords intended for use outdoors and so marked
19. **Stay alert**  
Watch what you are doing. Use common sense. Do not operate machine when you are tired.
20. **Check damaged parts**  
Before further use of the machine, a guard or other part that is damaged should be carefully checked to determine that it will operate properly and perform its intended function. Check for alignment of moving parts, binding of moving parts, breakage of parts, mounting, and any other conditions that may affect its operation. A guard or other part that is damaged should be properly repaired or replaced by an authorized service center unless otherwise indicated elsewhere in this instruction manual. Have defective switches replaced by an authorized service center. Do not use machine if switch does not turn it on and off.
21. **Warning**  
The use of any accessory or attachment other than recommended in this operating instruction or the catalog may present a risk of personal injury.
22. **Have your machine repaired by an expert**  
This electric appliance is in accordance with the relevant safety rules. Repairing of electric appliances may be carried out only by experts otherwise it may cause considerable danger for the user.

Save these instructions.

## **ADDITIONAL SAFETY RULES**

- 1. Wear hearing protection during extended periods of operation.**
- 2. Use only wheels having a maximum operating speed at least as high as “No Load RPM” marked on the tool’s nameplate. Use only fiberglass-reinforced cut-off wheels.**
- 3. Check the wheel carefully for cracks or damage before operation. Replace cracked or damaged wheel immediately.**
- 4. Secure the wheel carefully.**
- 5. Use only flanges specified for this tool.**
- 6. Be careful not to damage the spindle, flanges (especially the installing surface) or bolt, or the wheel itself might break.**
- 7. Keep guards in place and in working order.**
- 8. Hold the handle firmly.**
- 9. Keep hands away from rotating parts.**
- 10. Make sure the wheel is not contacting the workpiece before the switch is turned on.**
- 11. Before using the tool on an actual workpiece, let it simply run for several minutes first. Watch for flutter or excessive vibration that might be caused by poor installation or a poorly balanced wheel.**
- 12. Watch out for flying sparks when operating. They can cause injury or ignite combustible materials.**
- 13. Remove material or debris from the area that might be ignited by sparks. Be sure that others are not in the path of the sparks. Keep a proper, charged fire extinguisher closely available.**
- 14. Use the cutting edge of the wheel only. Never use side surface.**
- 15. If the wheel stops during the operation, makes an odd noise or begins to vibrate, switch off the tool immediately.**
- 16. Always switch off and wait for the wheel to come to a complete stop before removing, securing workpiece, working vise, changing work position, angle or the wheel itself.**
- 17. Do not touch the workpiece immediately after operation; it is extremely hot and could burn your skin.**
- 18. Store wheels in a dry location only.**

**SAVE THESE INSTRUCTIONS.**

## Removing or installing cut-off wheel

### CAUTION:

Always be sure that the machine is switched off and unplugged before removing or installing the wheel.

To remove the wheel, raise the safety cover, press the shaft lock so that the wheel cannot revolve and use the socket wrench to loosen the hex bolt by turning it counterclockwise. Then remove the hex bolt, outer flange and wheel.

To install the wheel, follow the removal procedures in reverse. **BE SURE TO TIGHTEN THE HEX BOLT SECURELY.**

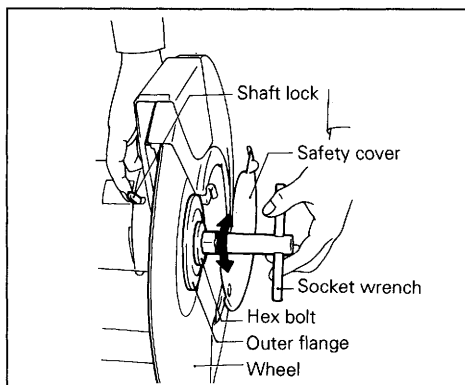

### CAUTION:

- When installing the wheel, make sure that the Makita mark on the wheel faces you on the outside.
- Use only the Makita socket wrench to remove or install the wheel.

## Changing interval between vise and guide plate

The spacing or interval between the vise and the guide plate can be adjusted according to the width of workpiece. To change the interval between the vise and the guide plate, loosen the hex bolts with the socket wrench and move the guide plate. Then tighten the hex bolts securely.

The following interval settings are possible:

0 – 155 mm (0 – 6-1/8")

35 – 190 mm (1-3/8" – 7-1/2")

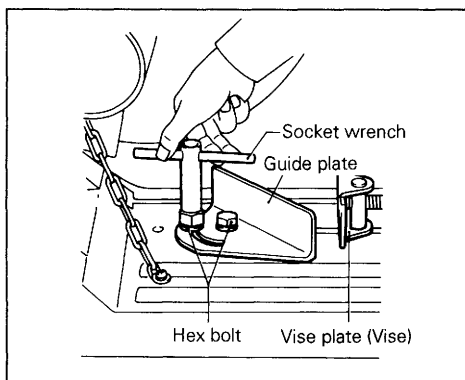

## Setting for desired cutting angle

To change the cutting angle, loosen the hex bolts with the socket wrench and move the guide plate to the desired angle. After adjusting the cutting angle, tighten the hex bolts securely.

### NOTE:

When the guide plate is set at the 35 – 190 mm (1-3/8" – 7-1/2") position, it cannot be angled to allow 45° cuts.

### Adjusting stopper plate

The stopper plate prevents the wheel from contacting the bench or floor surface while cutting.

After a new wheel is installed, adjust the stopper plate as shown in the figure and tighten the wing bolt securely.

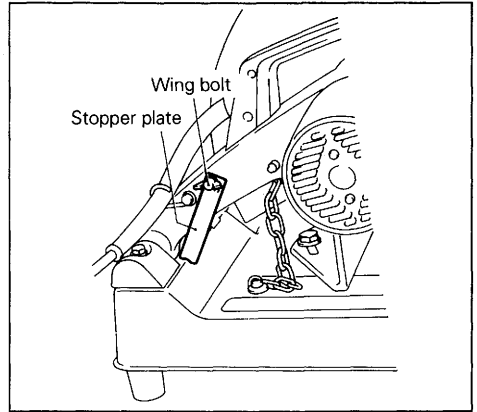

After the wheel wears down to below 280 mm (11") in diameter, set the stopper plate as shown in the figure and tighten the wing bolt securely.

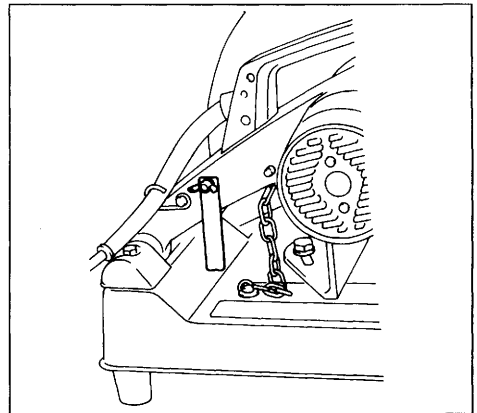

### CAUTION:

Be sure that the wheel does not contact the bench or floor surface before operation.

## Securing workpieces

This machine is equipped with a quick vise. By turning the handle on the vise counterclockwise and then turning the vise nut counterclockwise, the screw is released. The vise shaft can then be moved rapidly in and out. To grip workpieces, push the handle on the vise until the vise plate contacts the workpiece. Turn the vise nut clockwise and then turn the vise handle clockwise.

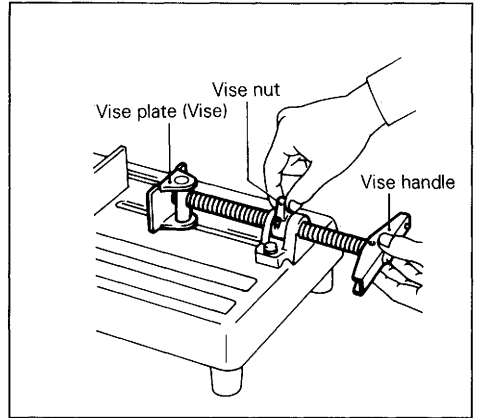

When securing this workpiece or when the cut-off wheel has worn down considerably, use a block of non-flammable material as shown in the figure so that you can cut the workpiece using the mid point on the periphery of the wheel.

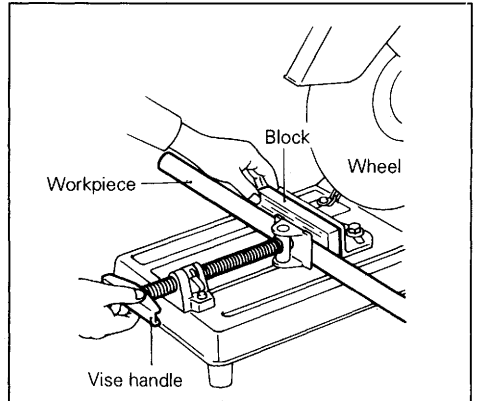

Long workpieces should be supported by blocks of some kind of non-flammable material on either side so that it will be level with the base top.

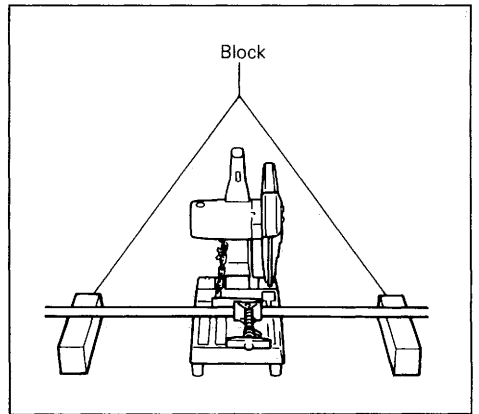

**Switch action**

**CAUTION:**

Before plugging in the machine, always check to see that the switch trigger actuated properly and returns to the "OFF" position when released.

To start the machine simply pull the trigger. Release the trigger to stop. For continuous operation, pull the trigger and then push in the lock button. To stop the machine from the locked position, pull the trigger fully, then release it.

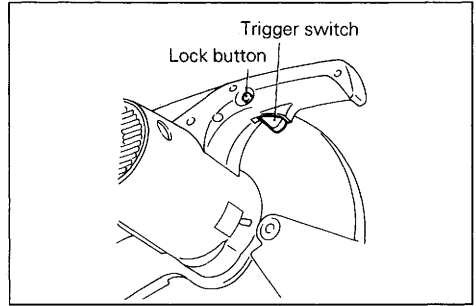

**Operation**

Hold the handle firmly. Switch on the machine and wait until the wheel attains full speed before lowering gently into the cut. When the wheel contacts the workpiece, gradually bear down on the handle to perform the cut. When the cut is completed, switch off the machine and WAIT UNTIL THE WHEEL HAS COME TO A COMPLETE STOP before returning the wheel to the fully elevated position.

**CAUTION:**

Proper handle pressure during cutting and maximum cutting efficiency can be determined by the amount of sparking that is visible while cutting. Your pressure on the handle should be adjusted to produce the maximum amount of sparking. Do not force the cut by applying excessive pressure on the handle. Reduced cutting efficiency, as well as, possible damage to the machine, cut-off wheel or workpiece may result.

**Cutting capacity**

Max. cutting capacity differs depending upon the cutting angle and workpiece configuration.

2414	90°	100 mm (4")	90 mm (3-1/2")	55 mm (2-1/8")	130 mm (5-1/8")
	45°	100 mm (4")	80 mm (3-1/8")	—	85 mm (3-3/8")
2412N	90°	100 mm (4")	85 mm (3-3/8")	45 mm (1-3/4")	100 mm (4")
	45°	100 mm (4")	85 mm (3-3/8")	—	85 mm (3-3/8")

Applicable wheel dimensions:

2414 305 mm (12") (Outer dia.) x less than 4.5 mm (3/16") (Thickness) x 25.4 mm (1") (Hole dia.)

2412N 355 mm (14") (Outer dia.) x less than 4.5 mm (3/16") (Thickness) x 25.4 mm (1") (Hole dia.)



## Carrying machine

Fold down the machine to position where you can attach the chain to hook on machine arm.

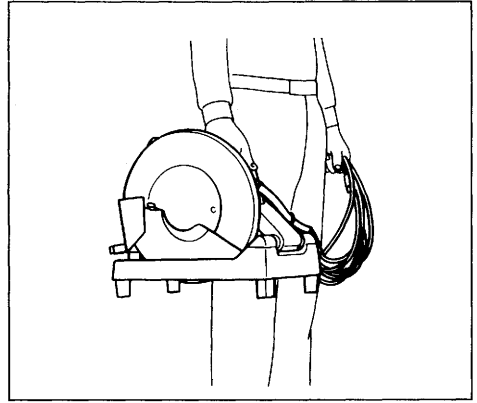
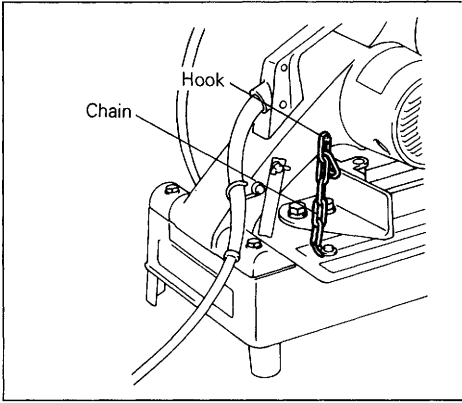

## MAINTENANCE

### CAUTION:

Always be sure that the machine is switched off and unplugged before attempting to perform inspection or maintenance.

### Replacing carbon brushes

Remove and check the carbon brushes regularly. Replace when they wear down to the limit mark. Keep the carbon brushes clean and free to slip in the holders. Both carbon brushes should be replaced at the same time. Use only identical carbon brushes.

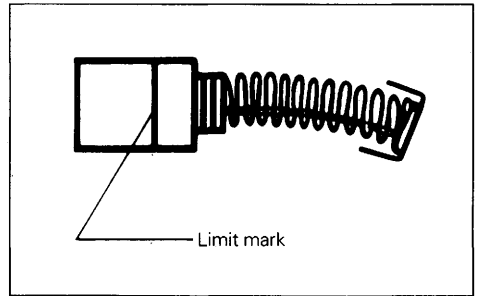

Use a screwdriver to remove the brush holder caps. Take out the worn carbon brushes, insert the new ones and secure the brush holder caps.

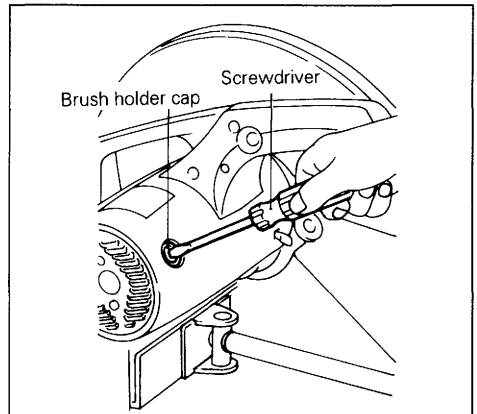

To maintain product SAFETY and RELIABILITY, repairs, any other maintenance or adjustment should be performed by Makita Authorized or Factory Service Centers, always using Makita replacement parts.



**Makita Corporation**

Anjo, Aichi Japan

Made in Japan

883839A4