

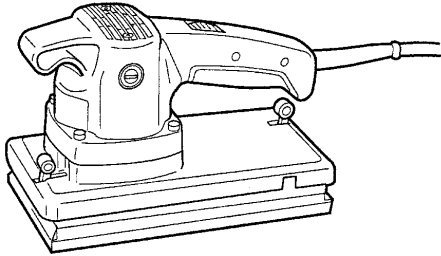

Finishing Sander

9045B

9045N



9045B

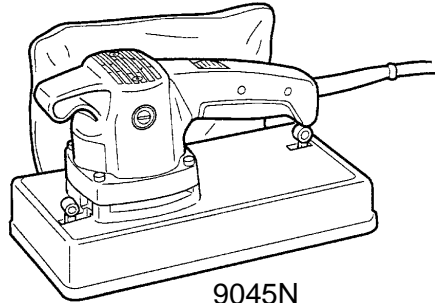

9045N



**DOUBLE
INSULATION**

SPECIFICATIONS

Model	9045B	9045N
Pad size	114 x 234 mm	114 x 234 mm
Orbits per minute	10,000	10,000
Overall length	240 mm	268 mm
Net weight	2.6 kg	2.8 kg

- Due to our continuing program of research and development, the specifications herein are subject to change without notice.
- Note: Specifications may differ from country to country.

Power supply

The tool should be connected only to a power supply of the same voltage as indicated on the nameplate, and can only be operated on single-phase AC supply. They are double-insulated in accordance with European Standard and can, therefore, also be used from sockets without earth wire.

Noise And Vibration Of Model 9045N

The typical A-weighted noise levels are
sound pressure level: 89 dB (A)
sound power level: 102 dB (A)
– Wear ear protection. –

The typical weighted root mean square acceleration value is not more than 2.5 m/s².

For European countries only

EC-DECLARATION OF CONFORMITY

The undersigned, Yasuhiko Kanzaki, authorized by Makita Corporation, 3-11-8 Sumiyoshi-Cho, Anjo, Aichi, 446 Japan declares that this product

(Serial No. : series production)

manufactured by Makita Corporation in Japan is in compliance with the following standards or standardized documents,

HD400, EN50144, EN55014, EN61000*

in accordance with Council Directives, 73/23/EEC, 89/336/EEC and 98/37/EC.

*from 1st Jan. 2001

Yasuhiko Kanzaki **CE 94**



Director

MAKITA INTERNATIONAL EUROPE LTD.

Michigan Drive, Tongwell, Milton Keynes,
Bucks MK15 8JD, ENGLAND

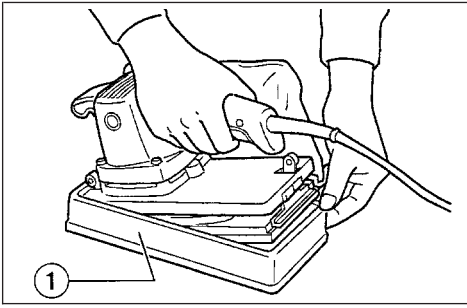

1

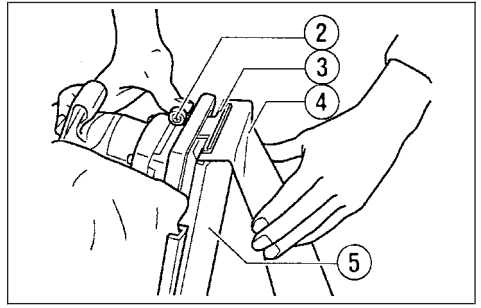

2

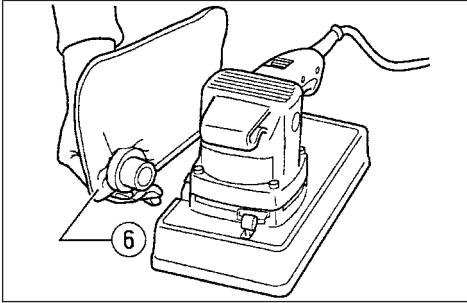

3

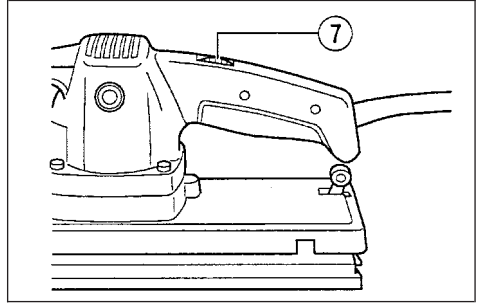

4

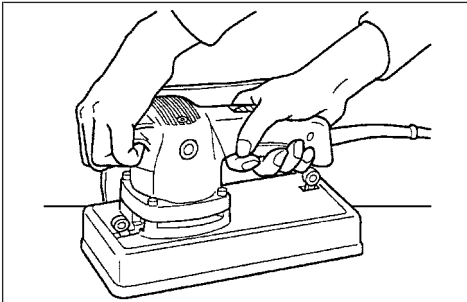

5

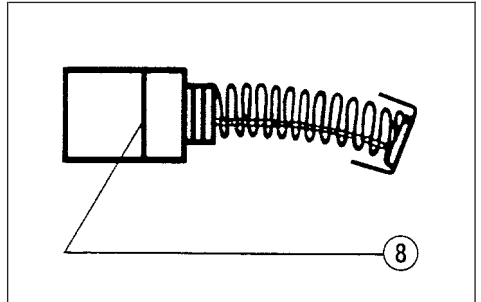

6

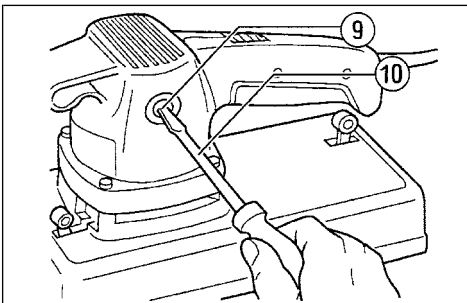

7

- | | | |
|------------------|----------------|--------------------|
| ① Frame cover | ⑤ Base | ⑧ Limit mark |
| ② Push button | ⑥ Dust bag | ⑨ Brush holder cap |
| ③ Clamper | ⑦ Slide switch | ⑩ Screwdriver |
| ④ Abrasive paper | | |

SAFETY INSTRUCTIONS

Warning! When using electric tools, basic safety precautions should always be followed to reduce the risk of fire, electric shock and personal injury, including the following.

Read all these instructions before attempting to operate this product and save these instructions.

For safe operation:

- 1. Keep work area clean**
Cluttered areas and benches invite injuries.
- 2. Consider work area environment**
Don't expose power tools to rain. Don't use power tools in damp or wet locations. Keep work area well lit. Don't use power tools in presence of flammable liquids or gases.
- 3. Guard against electric shock**
Prevent body contact with grounded surfaces (e.g. pipes, radiators, ranges, refrigerators).
- 4. Keep children away**
Do not let visitors contact tool or extension cord. All visitors should be kept away from work area.
- 5. Store idle tools**
When not in use, tools should be stored in dry, high, or locked-up place, out of the reach of children.
- 6. Don't force tool**
It will do the job better and safer at the rate for which it was intended.
- 7. Use right tool**
Don't force small tools or attachments to do the job of a heavy duty tool. Don't use tools for purposes not intended; for example, don't use circular saw for cutting tree limbs or logs.
- 8. Dress properly**
Do not wear loose clothing or jewelry. They can be caught in moving parts. Rubber gloves and non-skid footwear are recommended when working outdoors. Wear protective hair covering to contain long hair.
- 9. Use safety glasses and hearing protection**
Also use face or dust mask if cutting operation is dusty.
- 10. Connect dust extraction equipment**
If devices are provided for the connection of dust extraction and collection facilities, ensure these are connected and properly used.
- 11. Don't abuse cord**
Never carry tool by cord or yank it to disconnect it from receptacle. Keep cord from heat, oil and sharp edges.
- 12. Secure work**
Use clamps or a vise to hold work. It's safer than using your hand and it frees both hands to operate tool.

13. Don't overreach

Keep proper footing and balance at all times.

14. Maintain tools with care

Keep tools sharp and clean for better and safer performance. Follow instructions for lubricating and changing accessories. Inspect tool cords periodically and, if damaged, have repaired by authorized service facility. Inspect extension cords periodically and replace if damaged. Keep handles dry, clean and free from oil and grease.

15. Disconnect tools

When not in use, before servicing, and when changing accessories such as blades, bits and cutters.

16. Remove adjusting keys and wrenches

Form the habit of checking to see that keys and adjusting wrenches are removed from tool before turning it on.

17. Avoid unintentional starting

Don't carry plugged-in tool with finger on switch. Be sure switch is off when plugging in.

18. Outdoor use extension cords

When tool is used outdoors, use only extension cords intended for use outdoors and so marked.

19. Stay alert

Watch what you are doing. Use common sense. Do not operate tool when you are tired.

20. Check damaged parts

Before further use of the tool, a guard or other part that is damaged should be carefully checked to determine that it will operate properly and perform its intended function. Check for alignment of moving parts, binding of moving parts, breakage of parts, mounting, and any other conditions that may affect its operation. A guard or other part that is damaged should be properly repaired or replaced by an authorized service center unless otherwise indicated elsewhere in this instruction manual. Have defective switches replaced by and authorized service center. Do not use tool if switch does not turn it on and off.

21. Warning

The use of any other accessory or attachment other than recommended in this operating instruction or the catalog may present a risk of personal injury.

22. Have your tool repaired by an expert

This electric appliance is in accordance with the relevant safety rules. Repairing of electric appliances may be carried out only by experts otherwise it may cause considerable danger for the user.

ADDITIONAL SAFETY RULES

1. Hold the tool firmly.
2. Do not leave the tool running. Operate the tool only when hand-held.
3. This tool has not been waterproofed, so do not use water on the workpiece surface.

SAVE THESE INSTRUCTIONS.

OPERATING INSTRUCTIONS

Installing or removing abrasive paper (Fig. 1 & 2)

Important:

Always be sure that the tool is switched off and unplugged before installing or removing the paper.

First, remove the frame cover from either the front or back as shown in Fig. 1. (9045N only)

Push the push button to release the clasper. Insert the paper end into the clasper, aligning the paper edges even and parallel with the sides of the base. (Prebending the paper makes attachment easier.)

Repeat the same process for the other end of the base, maintaining the proper paper tension.

(9045B & 9045N)

Then replace the frame cover. (9045N only)

CAUTION:

After inserting the paper, make sure the teeth of the clasper hold it securely. Otherwise the paper will be loose and subject to slippage, resulting in uneven sanding operation.

Dust bag (Fig. 3)

9045N only

The use of the dust bag makes sanding operations clean and dust collection easy.

To attach the dust bag, fit the bag's entry port onto the dust spout on the tool, then turn it clockwise or counterclockwise so that the small hole in the port fits over the pin protruding from the spout.

To remove the dust bag, turn it counterclockwise to slip the hole off the pin, then pull off the dust bag. For the best results, empty the dust bag when it becomes about half full, tapping it lightly to remove as much dust as possible.

Switch action (Fig. 4)

To start the tool, move the slide switch forward. Move it backward to stop.

Operation (Fig. 5)

Hold the tool firmly. Turn the tool on and wait until it attains full speed. Then gently place the tool on the workpiece surface. A finishing sander is generally used to remove only a small amount of material at a time. Since the quality of the surface is more important than the amount of stock removed, do not bear down on the tool.

Keep the base flush with the workpiece at all times. Excessive pressure may damage the paper and shorten tool life.

You can put a high polish on furniture or other fine surfaces by using a cloth under the tool.

CAUTION:

- Do not block motor vent with your finger or hand.
- Never run the tool without paper. You may seriously damage the pad.

MAINTENANCE

CAUTION:

Always be sure that the tool is switched off and unplugged before carrying out any work on the tool.

Replacement of carbon brushes (Fig. 6 & 7)

Replace carbon brushes when they are worn down to the limit mark. Both identical carbon brushes should be replaced at the same time.

To maintain product safety and reliability, repairs, maintenance or adjustment should be carried out by a Makita Authorized Service Center.

ACCESSORIES

CAUTION:

These accessories or attachments are recommended for use with your Makita tool specified in this manual. The use of any other accessories or attachments might present a risk of injury to persons. The accessories or attachments should be used only in the proper and intended manner.

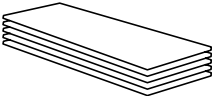
• Abrasive paper (with pre-punched holes)	Grit	Use	
	60	Coarse	
	80	Medium	
	100		
	120		
	150	Fine	
	180		

THE ADDITIONAL COMMENT OF ELECTRICAL CONNECTION

The tool is double insulated for safety, no earth connection is required.

CAUTION: The tool must be connected to a plug having a rated current greater than that of tool.
The rated voltage and current appear on the name plate.

IMPORTANT: The wires in the mains lead are coloured in accordance with the following code.

BLUE — NEUTRAL
BROWN — LIVE

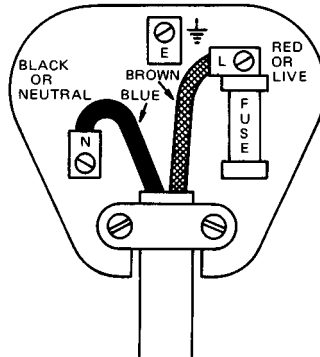

NOTE: As the colours of the mains lead of the tool may not correspond with the coloured markings identifying the terminals in your plug, proceed as follows:
THE WIRE WHICH IS COLOURED BLUE MUST BE CONNECTED TO THE TERMINAL WHICH IS MARKED WITH THE LETTER "N" OR COLOURED BLACK. THE WIRE WHICH IS COLOURED BROWN MUST BE CONNECTED TO THE TERMINAL WHICH IS MARKED WITH THE LETTER "L" OR COLOURED RED.

CAUTION: Neither wire is to be connected to earth terminal which is marked with the letter "E" or symbol "⏏".

FOR 110 VOLT TOOL, USE PLUGS TO BS4343.

Makita Corporation

Anjo, Aichi Japan

Made in Japan

883256D8